

NOTE: All Assembly Order Numbers are for bead plate parts unless noted otherwise.

	Description	Assembly Order No.
Style 113-1	Blind nuts, 1/4 BSP	W01-M58-6371
Two Ply Bellows	Blind nuts, 3/4 BSP	W01-M58-6369
	Rubber bellows only	W01-358-0150
Assembly weight.....		6.89 kg.
Force to collapse to minimum height (@ 0 BAR)		111 N.

Style 128-1	Blind nuts, 3/4 BSP	W01-M58-6066
High Strength Construction		

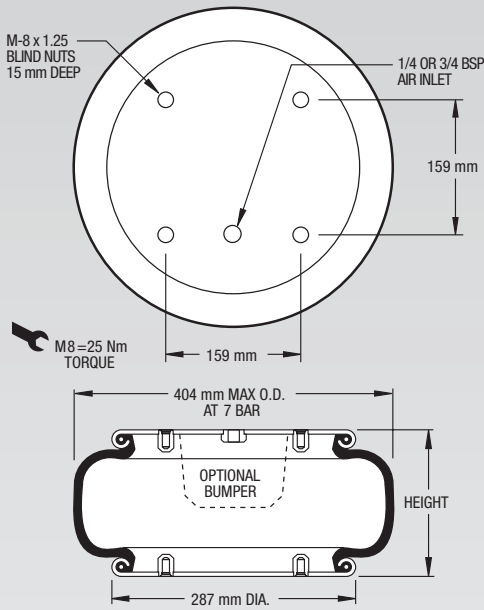

NOTE: A bead plate part is shown. This part is also available with bead rings. See pages 8-10 for explanation.

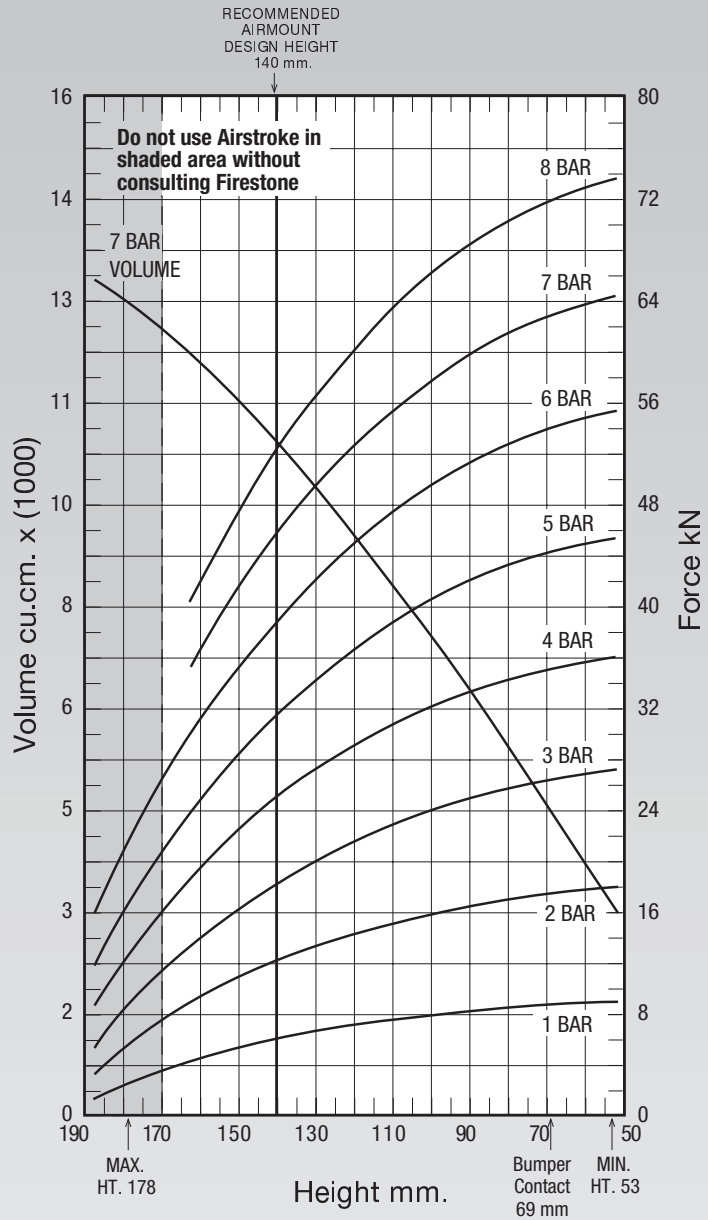

See page 12 for instructions on how to use chart.

Dynamic Characteristics at 140mm Design Height
(Required for Airmount isolator design only)

Gauge Pressure (BAR)	Load (kN)	Spring Rate (kN/m)	Natural Frequency Hz
3	18.07	416	2.39
4	24.76	529	2.31
5	31.33	646	2.27
6	38.72	771	2.23
7	45.44	887	2.20

Force Table (Use for Airstroke™ actuator design)

Assembly Height (mm)	Volume @ 7 BAR (cu cm)	EFF Area @ 7 BAR (cm sq.)	kN Force				
			@ 3 BAR	@ 4 BAR	@ 5 BAR	@ 6 BAR	@ 7 BAR
160	11771	516	13.58	19.08	24.39	30.59	36.10
140	10492	649	18.07	24.76	31.33	38.72	45.44
120	9061	750	21.39	28.92	36.48	44.84	52.49
100	7479	825	23.91	32.03	40.34	49.41	57.72
80	5781	878	25.75	34.28	43.15	52.69	61.43
60	4002	911	26.85	35.69	44.94	54.78	63.79