**WARNING:**

Do not inflate this assembly when it is unrestricted. The assembly must be restricted by the suspension or other adequate structure. Do not inflate beyond 100 P.S.I. Improper use or over inflation may cause property damage or severe personal injury.

Firestone Industrial Products
Carmel, Indiana, USA

INSTALLATION INSTRUCTIONS

Congratulations - your new Air Helper Springs are quality products capable of improving the handling and comfort of your vehicle. As with all products, proper installation is the key to obtaining all of the benefits your kit is capable of delivering. Please take a few minutes to read through the instructions to identify the components and learn where and how they are used. It is a good idea to start by comparing the parts in your kit with the parts list below.

The heart of the air spring kit is, of course, the air helper springs. Remember that the air helper springs must flex and expand during operation, so be sure that there is enough clearance to do so without rubbing against any other part of the vehicle.

Be sure to take all applicable safety precautions during the installation of the kit. The instructions listed in this brochure and the illustrations all show the left, or driver's side of the vehicle. To install the right side assembly simply follow the same procedures.

This kit includes inflation valves and air lines for each air spring. This will allow you to compensate for unbalanced loads. If you would rather have a single inflation valve system to provide equal pressure to both air springs, your dealer can supply the optional "T" fitting.

IMPORTANT!

For your safety and to prevent possible damage to your vehicle, do not exceed the maximum load recommended by the vehicle manufacturer (GVWR). Although your Air Helper Springs are rated at a maximum inflation pressure of 100 psi, this pressure may allow you to carry too great a load on some vehicles. It is best to have your vehicle weighed once it is completely loaded and compare that weight to the maximum allowed. Check your vehicle owner's manual or data plate on driver side door for maximum loads listed for your vehicle.

When inflating your Air Helper Springs, add air pressure in small quantities, checking pressure frequently during inflation. The air spring requires much less air volume than a tire and, therefore, inflates much quicker.

PARTS LIST

AIR SPRING	6397	2	5/8"-18 JAM NUT	2
UPPER BRACKET	5542	2	5/8" FLAT WASHER	2
LOWER BRACKET	5543	2	5/16" FLAT WASHER	4
1/2" BRACKET STRAP	5086	4	ELBOW FITTING	3128
18 ft. TUBING		1	INFLATION VALVE	3032
3/8"-16 x 3-1/2" CARRIAGE BOLT		8	NYLON TIES	6
3/8"-16 FLANGE LOCK NUT		8	THERMAL SLEEVE	2
3/8"-16 x 3/4" FLANGE BOLT		2	CAUTION TAG	2

NOTE: Both illustrations are of the left, or driver's side of the vehicle.
Reverse any orientations when assembling and installing the right, or passenger's side of the vehicle.

FIGURE "A"

KIT ASSEMBLY

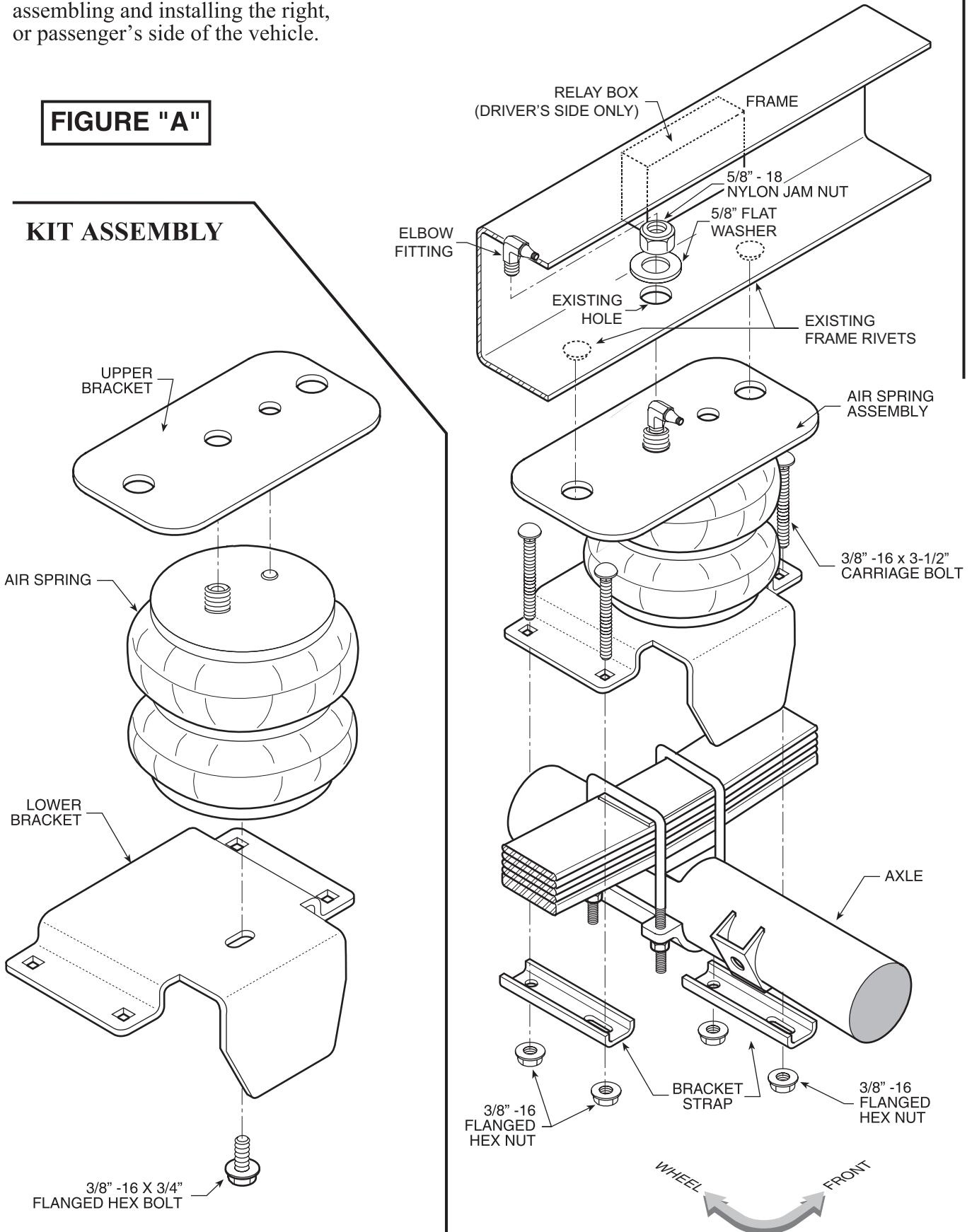

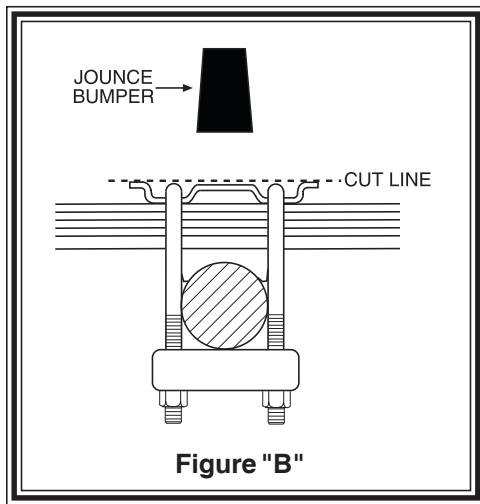

Figure "B"

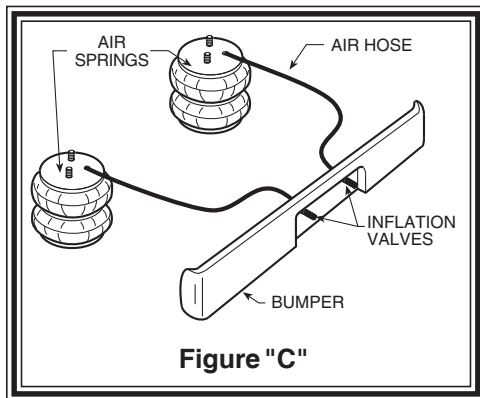

Figure "C"

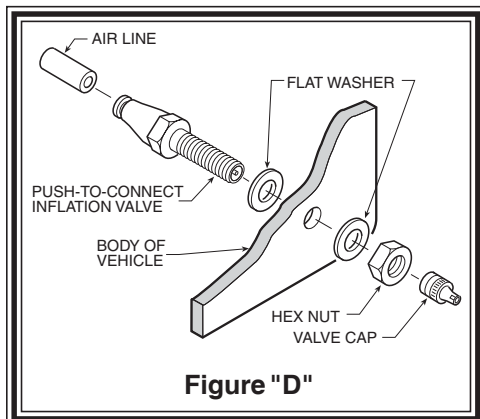

Figure "D"

STEP 1 - PREPARE THE VEHICLE

Place the vehicle on a solid level surface. Take necessary safety precautions such as using wheel chocks when working under your vehicle. Remove the jounce bumpers by cutting them off as close to the bracket as possible as shown in *Figure "B"*. Next, loosen the two nuts on the fuel relay box and move to the side.

STEP 2 - PREASSEMBLE THE KIT

Select an upper bracket and an air spring from your kit. Place the bracket on top of the air spring so the alignment pin inserts into the small middle hole, and the large combination stud inserts into the large middle hole. Attach the lower bracket to the air spring using the 3/8" - 16 x 3/4" hex bolt. Tighten the bolt making sure the bracket is in the correct position (*see Figure "A"*).

STEP 3 - INSTALL THE PREASSEMBLY TO THE VEHICLE

Place the preassembly on the leaf stack of the vehicle as shown in *Figure "A"*. *The emergency brake line bracket may need to be bent slightly for proper clearance.* Align the two rivets on the bottom of the frame with the large holes on the outside of the upper bracket. Insert the large combination stud into the existing hole on the bottom of the frame. Install the 5/8" washer and the 5/8" - 18 nylock jam nut onto the combination stud and tighten. *See Figure "A"*. Install the elbow fitting into the air spring. Tighten the air fitting hand tight, then 3/4 of a turn with a wrench. **DO NOT OVER TIGHTEN.** If the nylon ring is crushed, it will cause an air leak. (*see Figure "A"*). Attach the lower bracket to the leaf stack using the 3-1/2" carriage bolts, 3/8" lock nuts, and bracket straps as shown in *Figure "A"*. Replace the fuel relay box.

Follow the same procedures as outlined in steps 1 through 3 for installing the right side of the vehicle.

STEP 4 - INSTALL THE AIR LINE

Uncoil the air tubing and cut it into two equal lengths. **DO NOT FOLD OR KINK THE TUBING.** The air line tubing should not be bent or curved sharply as it may buckle with age.

Make the cut as square as possible. Insert one end of the tubing into the elbow fitting installed in the top of the air helper spring.

Select a location on the vehicle for the air inflation valves. The locations can be on the bumper or the body of the vehicle but be sure that it is in a protected location so the valve will not be damaged yet still be accessible for the air chuck (*see Figure "C"*). Drill a 5/16" hole or use an existing hole and install the air inflation valve using two 5/16" stainless steel flat washers per valve as supports (*see Figure "D"*). Run the tubing from the air spring to the inflation valve, routing it to avoid direct heat from the muffler or tailpipe, and away from sharp edges. Tubing protectors have been provided for these conditions. Push the end of the air line tubing into the inflation valve as illustrated (*see Figure "D"*). Secure the tubing in place with the nylon ties provided.

STEP 5 - CHECK THE AIR SYSTEM

Once the inflation valves are installed, inflate the air springs and check the fittings for air leaks with an applied solution of soap and water. If a leak is detected at a tubing connection then check to make sure that the tube is cut as square as possible and that it is pushed completely into the fitting. The tubing can easily be removed from the fittings by pushing the collar towards the body of the fitting and then pulling out the tube. If a leak is detected where the fitting screws into the spring, screw the elbow into the spring until the leak stops. Reinflate the air helper springs and check for leaks as noted above. Further information on trouble-shooting can be found in the General Operation Instruction book included with this kit.

This now completes the installation. Before proceeding, check once again to be sure you have proper clearance around the bellows. ***With a load on your vehicle and the helper air springs inflated, you must have at least 1/2" clearance around the bellows.*** As a general rule, the Ride-Rite Air Helper Springs will support approximately 32 lbs. of load for each p.s.i. of inflation pressure (per pair). For example, 50 P.S.I. of inflation pressure will support a load of 1600 lbs. per pair of air helper springs. FOR BEST RIDE use only enough air pressure in the air helper springs to level the vehicle when viewed from the side (front to rear). This amount will vary depending on the load, location of load, condition of existing suspension and personal preference.

NOTE: Too much air pressure in the helper springs will result in stiffer ride, while too little air pressure will allow the air spring to bottom out over rough conditions. Too little air pressure will also not provide the improvement in handling that is possible. ***TO PREVENT POSSIBLE DAMAGE MAINTAIN A MINIMUM OF 5 P.S.I. IN THE RIDE-RITE AIR SPRINGS AT ALL TIMES.***

NOTE:

Once the air helper springs are installed, it is recommended that the vehicle not be lifted by the frame, as over-extension may occur, resulting in damage to the air helper springs. However, should it become necessary to raise the vehicle by the frame, deflate both air helper springs completely.

NOTE:

MIN PRESSURE	5 PSI
MAX PRESSURE (LOADED)	100 PSI

