**WARNING:**

Do not inflate this assembly when it is unrestricted. The assembly must be restricted by the suspension or other adequate structure. Do not inflate beyond 100 P.S.I. Improper use or over inflation may cause property damage or severe personal injury.

INSTALLATION INSTRUCTIONS

Congratulations - your new air helper springs are quality products capable of improving the handling and comfort of your vehicle. As with all products, proper installation is the key to obtaining all of the benefits your kit is capable of delivering. Please take a few minutes to read through the instructions to identify the components and learn where and how they are used. It is a good idea to start by comparing the parts in your kit with the parts list below.

The heart of the air helper spring kit is, of course, the air springs. Remember that the air helper springs must flex and expand during operation, so be sure that there is enough clearance to do so without rubbing against any other part of the vehicle.

Be sure to take all applicable safety precautions during the installation of the kit. The instructions listed in this brochure and the illustrations all show the left or driver's side of the vehicle. To install the right side assembly simply follow the same procedures while reversing any orientations.

Your kit includes separate inflation valves and air lines for each air helper spring. This will allow you to level your vehicle from side to side as well as from front to back. If you would rather have a single valve inflation system, your dealer can supply the required T-fittings.

IMPORTANT!

For your safety and to prevent possible damage to your vehicle, do not exceed the maximum load recommended by the vehicle manufacturer (GVWR). Although your Air Helper Springs are rated at a maximum inflation pressure of 100 psi, this pressure may allow you to carry too great a load on some vehicles. It is best to have your vehicle weighed once it is completely loaded and compare that weight to the maximum allowed. Check your vehicle owner's manual or data plate on driver side door for maximum loads listed for your vehicle.

When inflating your Air Helper Springs, add air pressure in small quantities, checking pressure frequently during inflation. The air spring requires much less air volume than a tire and, therefore, inflates much quicker.

PARS LIST

AIR SPRING	9000	2	18 FT. AIR LINE	0938	1
UPPER BRACKET	5498	2	PUSH-TO-CONNECT		
LOWER BRACKET	5499	2	MALE CONNECTOR	3101	2
DISC	5204	2	INFLATION VALVE	3098	2
BRACKET STRAP	5086	2	VALVE CAP	3099	2
3/8" -16 x 3/4" FLANGED HEX BOLT		6	5/16" FLAT WASHER	3033	4
3/8" -16 FLANGED HEX NUT		4	THERMAL SLEEVE	0899	2
3/8" -16 x 2 CARRIAGE BOLT		4	NYLON TIE		6

NOTE: Both illustrations are of the right, or passenger's side of the vehicle.
Reverse any orientations when assembling and installing the left, or driver's side of the vehicle.

KIT TO FRAME ASSEMBLY

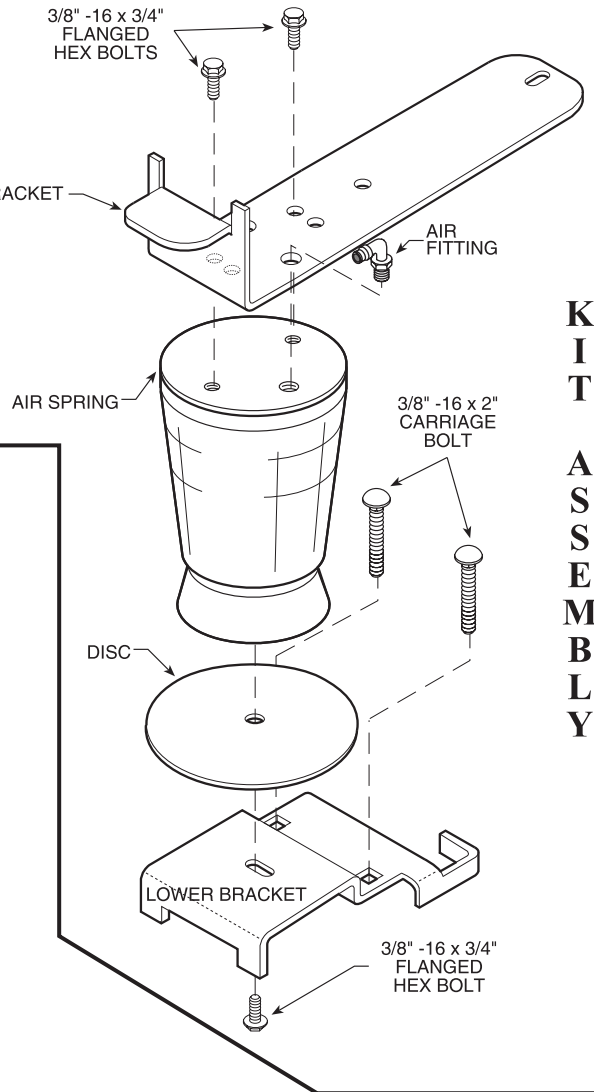

**K
I
T
A
S
S
E
M
B
L
Y**

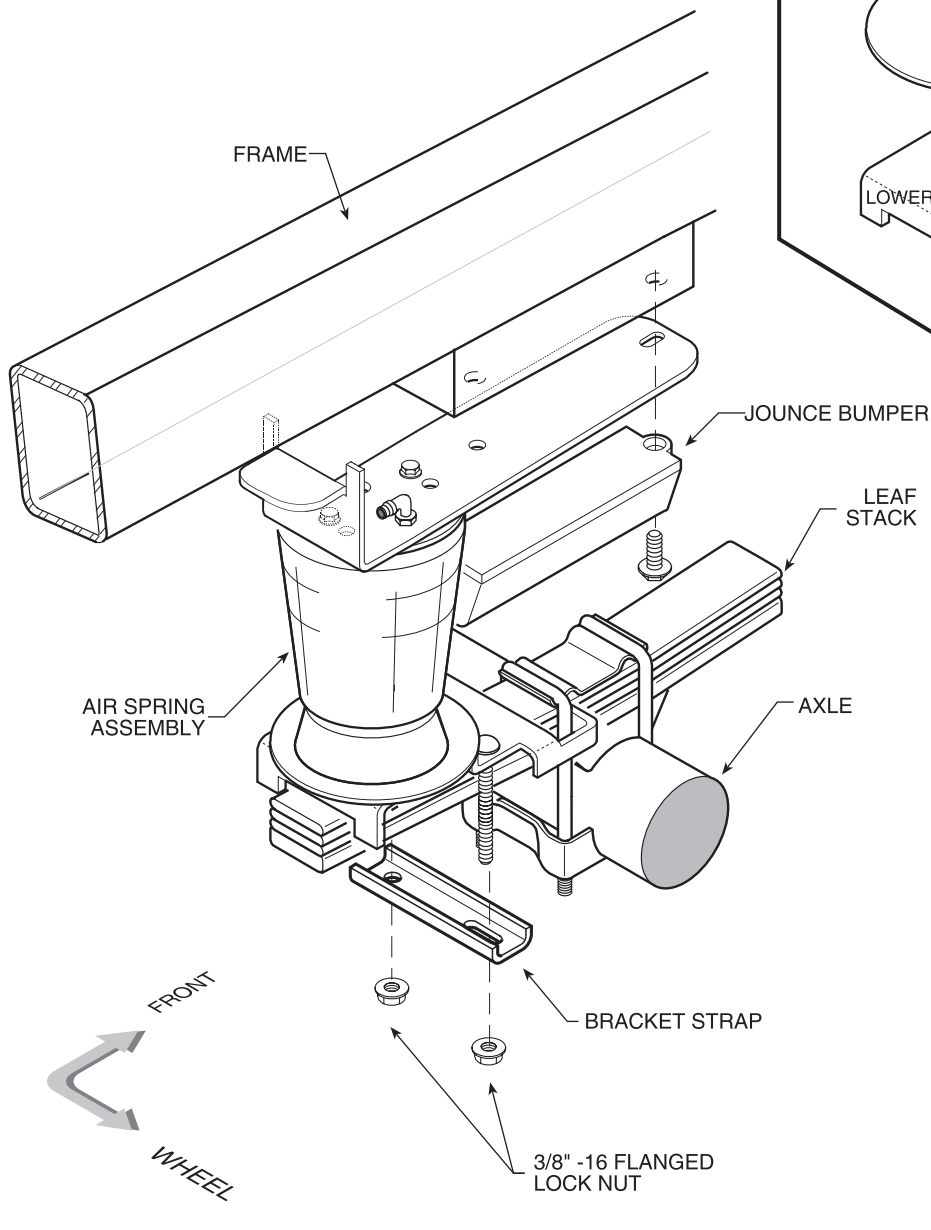

FIGURE "A"

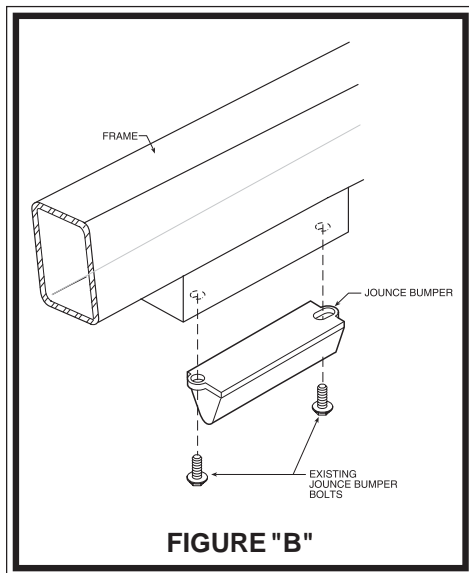

FIGURE "B"

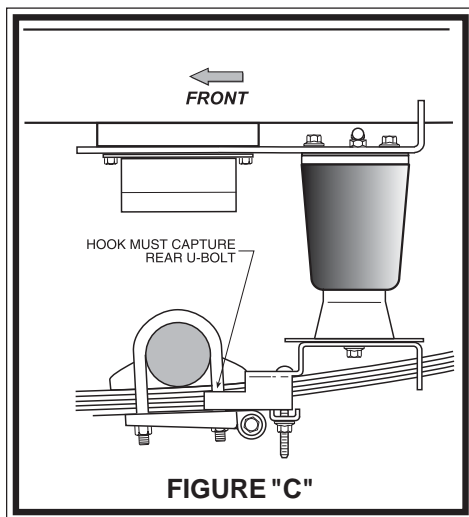

FIGURE "C"

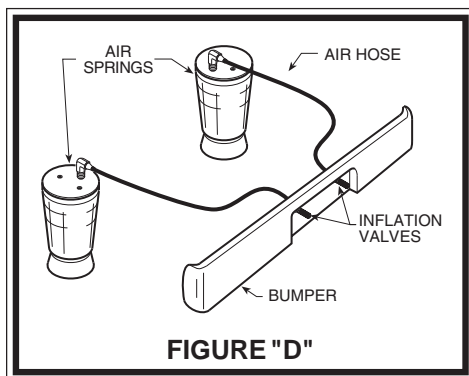

FIGURE "D"

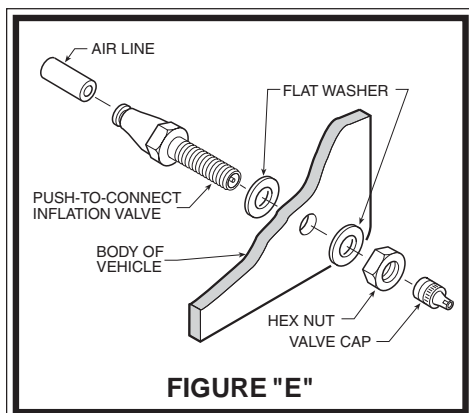

FIGURE "E"

STEP 1 - PREPARE THE VEHICLE

With the vehicle on a solid level surface, chock the front wheels. Using a lift or platform jack, raise the rear of the vehicle and set the axle on jack stands rated for your vehicle's weight. Remove the negative battery cable. Remove the jounce bumpers by unbolting them from the frame, *see Figure "B"*. Save the jounce bumpers and hex bolts used to secure the jounce bumpers to the frame. They will be reused in this installation.

STEP 2 - PREASSEMBLE THE KIT

Pre-assembly will begin with the right side of the vehicle. All pictures show the installation on the right side of the vehicle unless noted otherwise. Select one air helper spring and an upper bracket from your kit. Attach the upper bracket to the air helper spring using two of the 3/8" flanged hex bolts. Install the air fitting into the threaded hole in the top of the air spring. Tighten the air fitting so as to make contact with the nylon ring and then tighten 1/4 turn to snug the fitting. No thread sealant is required on the air fitting. Select a lower bracket and disc from your kit. Insert the two 3/8" -16 x 2" carriage bolts through the square holes in the lower bracket. Install the disk between the bottom of the air spring and the lower bracket. Align the mounting hole in the lower bracket with the hole in the bottom of the air spring, *see Figure "A"*. Fasten the lower bracket to the air spring using a 3/8" -16 x 3/4" flanged hex bolt (*finger tight*).

STEP 3 - INSTALL THE ASSEMBLY TO THE VEHICLE

It will not be necessary to drill holes in the frame rail to install the kit. The upper bracket will be fastened to the frame rail using two existing holes. Position the air spring assembly on top of the leaf spring just behind the axle, *see Figure "A"*. The hook on the lower bracket must capture the leaf spring retaining bolt behind the axle, *see Figure "C"*. It may be necessary to compress the air spring assembly to properly position the upper bracket. Install the bracket strap over the carriage bolts and against the bottom of the leaf stack. Secure the bracket strap to the leaf stack with two 3/8" -16 flanged hex nuts.

Align the upper bracket so that the vertical tabs on the bracket straddle the frame rail. Reinstall the jounce bumper using the existing jounce bumper bolts through the jounce bumper and the upper bracket and into the bottom of the frame rail, *see Figure "A"*.

Tighten the 3/8" -16 x 3/4" flanged hex bolt securing the air spring to the lower bracket.

STEP 4 - INSTALL THE PASSENGER'S SIDE ASSEMBLY

To install the left side assembly, follow Steps 2-3 while reversing any orientations.

STEP 5 - INSTALL THE AIR LINE

Uncoil the air tubing and cut it into two equal lengths. **DO NOT FOLD OR KINK THE TUBING**. Try to make the cut as square as possible. Insert one end of the tubing into the elbow fitting installed in the top of the air helper spring. Push the tubing into the fitting as far as possible. Select a location on the vehicle for the air inflation valves. The location can be on the bumper or the body of the vehicle, as long as it is in a protected location so the valve will not be damaged, but maintain accessibility for the air chuck, *see Figure "D"*. Drill a 5/16" hole and install the air inflation valve using two 5/16" flat washers per valve as supports, *see Figure "E"*. Run the tubing from the air spring to the inflation valve, avoiding direct heat from the engine, exhaust, and away from sharp edges. Thermal sleeves have been provided for these conditions. If a thermal sleeve is required, slide a thermal sleeve over the tubing to the location requiring protection. The air line tubing should not be bent or curved sharply, as it may buckle. Secure the tubing to the vehicle with the provided nylon ties. Push the end of the air line tubing into the inflation valve as illustrated, *see Figure "E"*.

STEP 6 - CHECK THE AIR SYSTEM

Once the inflation valves are installed, inflate the air helper springs to 70 P.S.I. and check the fittings for air leaks with an applied solution of soap and water. If a leak is detected at a tubing connection, check to make sure that the tube is cut as squarely as possible and that it is pushed completely into the fitting. The tubing can easily be removed from the fittings. First, release the air pressure from the air springs. Push the collar towards the body of the fitting and then pull out the tube. If a leak is detected where the air fitting screws into the air spring, remove the tubing, then tighten the air fitting in the air spring until the leak stops. Reinstall the tubing and reinflate the air springs and check for leaks as noted above.

This now completes the installation. Before proceeding, check once again to be sure you have proper clearance around the air springs. With a load on your vehicle and the air helper springs inflated, you must have at least 1/2" clearance around the air springs. As a general rule, the air helper springs will support approximately 30 lbs. of load for each psi of inflation pressure (per pair). For example, 50 psi of inflation pressure will support a load of 1500 lbs. per pair of air helper springs. *FOR BEST RIDE* use only enough air pressure in the air helper springs to level the vehicle when viewed from the side (front to rear). This amount will vary depending on the load, location of load, condition of existing suspension and personal preference.

NOTE:

Too much air pressure in the helper springs will result in a firmer ride, while too little air pressure will allow the air helper spring to bottom out over rough conditions. Too little air pressure will also not provide the improvement in handling that is possible. ***TO PREVENT POSSIBLE DAMAGE, MAINTAIN A MINIMUM OF 10 P.S.I. IN THE AIR HELPER SPRINGS AT ALL TIMES.***

NOTE:

Once the air helper springs are installed, it is recommended that the vehicle not be lifted by the frame, as over-extension may occur, resulting in damage to the air springs. However, should it become necessary to raise the vehicle by the frame, deflate both air helper springs completely.

NOTE:

MIN PRESSURE	5 PSI
MAX PRESSURE (LOADED)	100 PSI



www.riderite.com