

| Description | | Assembly Order No. |
|---|--|--------------------|
| Style 113-1 | Blind nuts, 1/4 NPT | WO1-358-7091 |
| | Blind nuts, 3/4 NPT | WO1-358-7092 |
| Two Ply Bellows | Blind nuts, 3/4 NPT, rubber bumper | WO1-358-7094 |
| | Countersunk steel bead rings, 1 3/4 bolts, nuts, washers | WO1-358-7277 |
| | Rubber bellows only | WO1-358-0150 |
| Assembly weight | | 15.2 lbs. |
| Force to collapse to minimum height (@ 0 PSIG)..... | | 25 lbs. |

| | | |
|-----------------------|---------------------|--------------|
| Style 128-1 | Blind nuts, 3/4 NPT | WO1-358-8160 |
| High Strength Bellows | | |

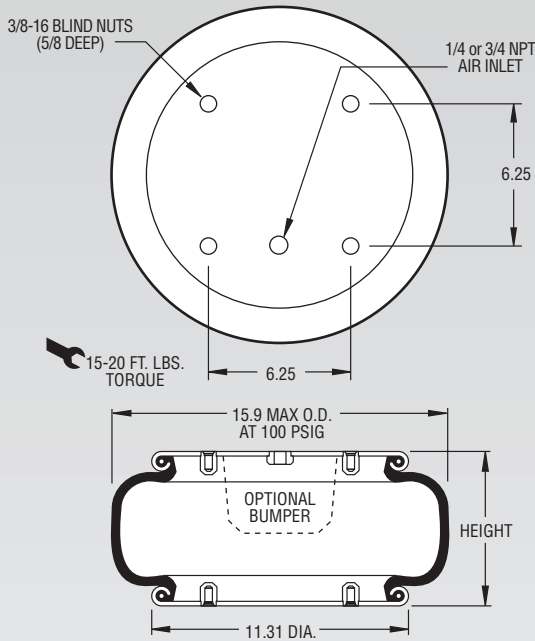

NOTE: A bead plate part is shown. This part is also available with bead rings. See pages 8-10 for explanation.

| Dynamic Characteristics at 5.5 in. Design Height (Required for Airmount isolator design only) | | | | |
|--|-------------|------------------------|-------------------|------|
| Volume @ 100 PSIG = 641 in ³ | | | Natural Frequency | |
| Gage Pressure (PSIG) | Load (lbs.) | Spring Rate (lbs./in.) | CPM | HZ |
| 40 | 3,820 | 2,198 | 142 | 2.37 |
| 60 | 5,900 | 3,091 | 136 | 2.26 |
| 80 | 7,990 | 3,986 | 133 | 2.21 |
| 100 | 10,200 | 4,923 | 130 | 2.17 |

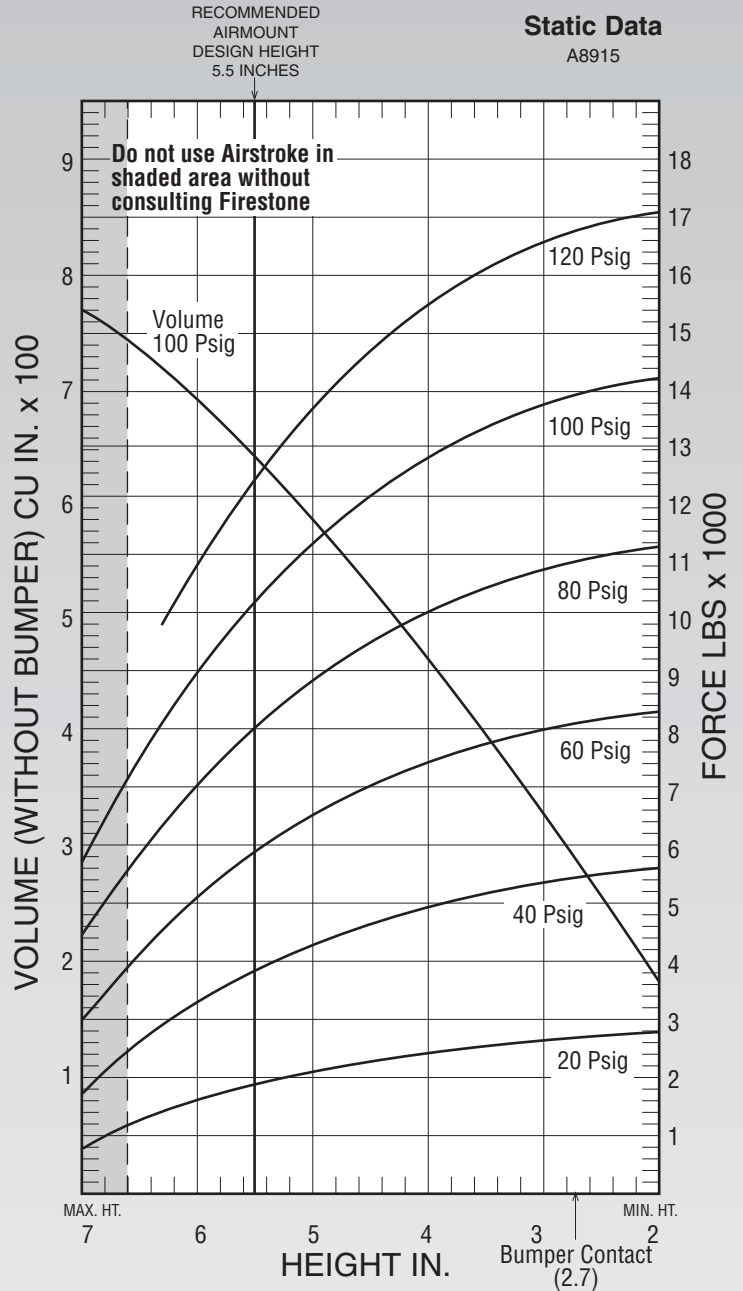

See page 12 for instructions on how to use chart.

| Force Table (Use for Airstroke® actuator design) | | | | | | |
|--|--------------------------------------|--------------|----------|----------|----------|-----------|
| Assembly Height (in.) | Volume @ 100 PSIG (in ³) | Pounds Force | | | | |
| | | @20 PSIG | @40 PSIG | @60 PSIG | @80 PSIG | @100 PSIG |
| 6.0 | 692 | 1,600 | 3,270 | 5,130 | 7,000 | 8,990 |
| 5.0 | 586 | 2,070 | 4,260 | 6,530 | 8,800 | 11,200 |
| 4.0 | 463 | 2,440 | 4,940 | 7,470 | 10,080 | 12,710 |
| 3.0 | 328 | 2,660 | 5,360 | 8,060 | 10,860 | 13,630 |