

Description		Assembly Order No.
Style 116	Blind nuts, 1/4 NPT	WO1-358-7564
	Blind nuts, 3/4 NPT	WO1-358-7561
Two Ply Bellows	Countersunk steel bead rings, 1 ³ / ₄ bolts, nuts, washers	WO1-358-7568
	Blind nuts with installed 1/4 tank valve	WO1-A72-7518
	Rubber bellows only	WO1-358-0133
Assembly weight		4.3 lbs.
Force to collapse to minimum height (@ 0 PSIG).....		8 lbs.
Style 117	Blind nuts, 1/4 NPT	WO1-358-7600
	Blind nuts, 3/4 NPT	WO1-358-7602
High Strength Bellows	Countersunk steel bead rings, 1 ³ / ₄ bolts, nuts, washers	WO1-358-7606

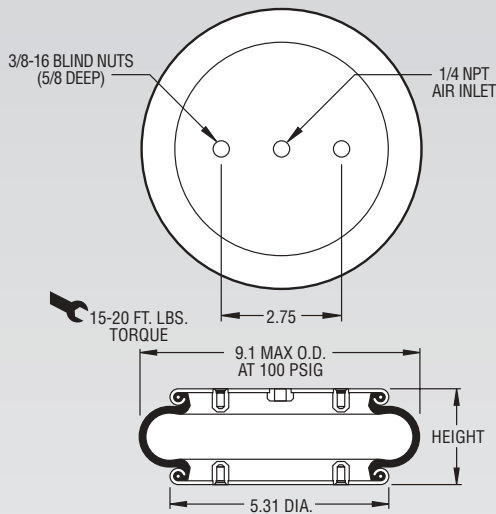

NOTE: A bead plate part is shown. This part is also available with bead rings. See pages 8-10 for explanation.

Dynamic Characteristics at 4.5 in. Design Height (Required for Airmount isolator design only)				
Volume @ 100 PSIG = 149 in ³			Natural Frequency	
Gage Pressure (PSIG)	Load (lbs.)	Spring Rate (lbs./in.)	CPM	HZ
40	850	736	175	2.91
60	1,330	1,070	168	2.80
80	1,830	1,374	163	2.71
100	2,360	1,688	159	2.65

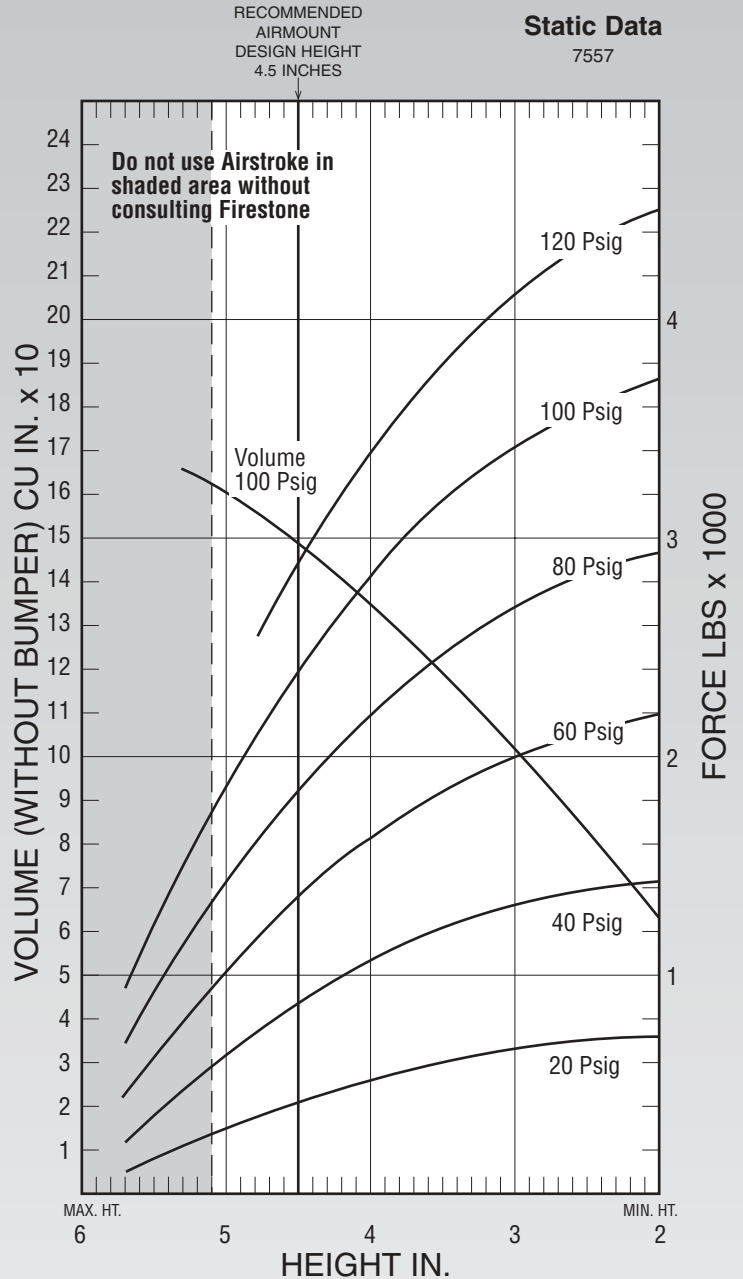

See page 12 for instructions on how to use chart.

Force Table (Use for Airstroke® actuator design)						
Assembly Height (in.)	Volume @ 100 PSIG (in ³)	Pounds Force				
		@20 PSIG	@40 PSIG	@60 PSIG	@80 PSIG	@100 PSIG
5.0	161	290	600	970	1,370	1,800
4.0	135	520	1,050	1,630	2,210	2,820
3.0	102	650	1,310	2,000	2,690	3,410