

Description		Assembly Order No.
Style 126	Ribbed neck aluminum bead rings (equal spacing), 1 7/8 bolts, nuts, washers	WO1-358-7727
Two Ply Bellows	Rolled Plate Assembly, 1/2 blind nuts, 3/4 NPT	WO1-358-7726
Assembly weight		21.3 lbs.
Force to collapse to minimum height (@ 0 PSIG).....		25 lbs.

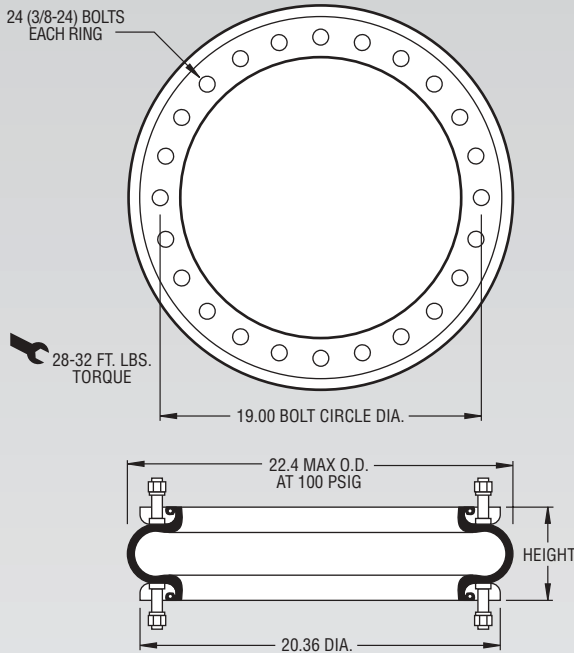

NOTE: A bead ring part is shown. This part is also available with rolled plates. See page 11 for explanation.

Dynamic Characteristics at 5.0 in. Design Height (Required for Airmount isolator design only)				
Volume @ 100 PSIG = 1,315 in ³			Natural Frequency	
Gage Pressure (PSIG)	Load (lbs.)	Spring Rate (lbs./in.)	CPM	HZ
40	11,030	6,237	141	2.35
60	16,710	8,763	136	2.26
80	22,460	11,345	133	2.22
100	28,290	13,751	131	2.18

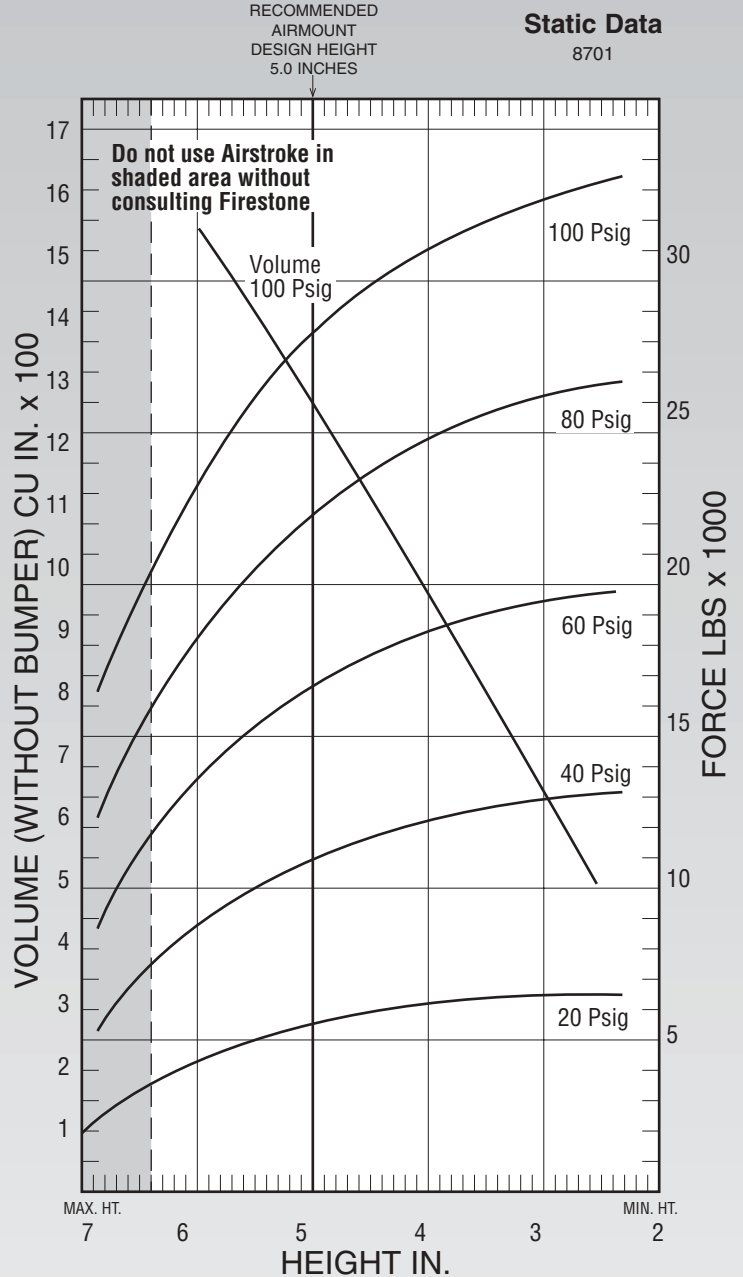

See page 12 for instructions on how to use chart.

Force Table (Use for Airstroke® actuator design)						
Assembly Height (in.)	Volume @ 100 PSIG (in ³)	Pounds Force				
		@20 PSIG	@40 PSIG	@60 PSIG	@80 PSIG	@100 PSIG
6.0	1,589	4,390	8,880	13,580	18,360	23,450
5.0	1,315	5,560	11,030	16,710	22,460	28,290
4.0	1,007	6,120	12,120	18,330	24,660	30,930
3.0	676	6,440	12,830	19,330	25,990	32,600