

Description		Assembly Order No.
Style 1T12E-3	Blind nuts, 1/4 NPT	WO1-358-8119
Two Ply Bellows	Socket head aluminum bead ring (bolts, nuts, washers not included, use cap screws)	WO1-358-8118
Assembly weight		3.5 lbs.

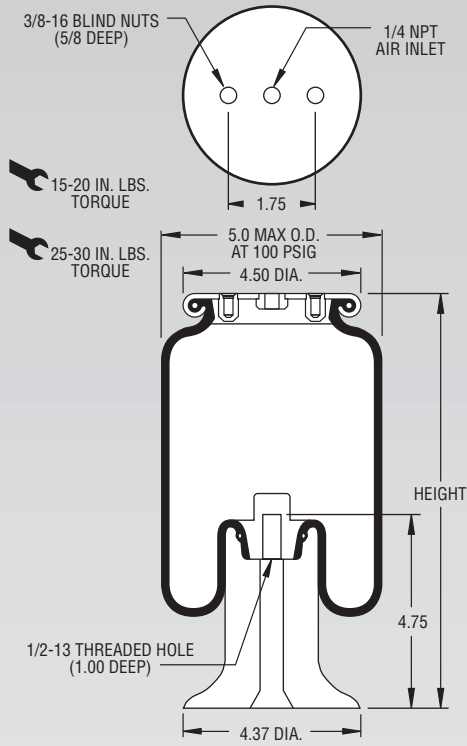

NOTE: Bellows will not compress properly with less than 10 PSIG internal pressure.

NOTE: A bead plate part is shown. This part is also available with a bead ring. Bolts are not included. See pages 8-10 for explanation.

Dynamic Characteristics at 10.5 in. Design Height (Required for Airmount isolator design only)				
Volume @ 100 PSIG = 89 in ³			Natural Frequency	
Gage Pressure (PSIG)	Load (lbs.)	Spring Rate (lbs./in.)	CPM	HZ
40	290	53	81	1.35
60	450	75	77	1.28
80	600	91	73	1.22
100	770	114	72	1.21

CONSULT FIRESTONE BEFORE USING AS AIRMOUNT

RECOMMENDED AIRMOUNT DESIGN HEIGHT 10.5 INCHES

Static Data
9232

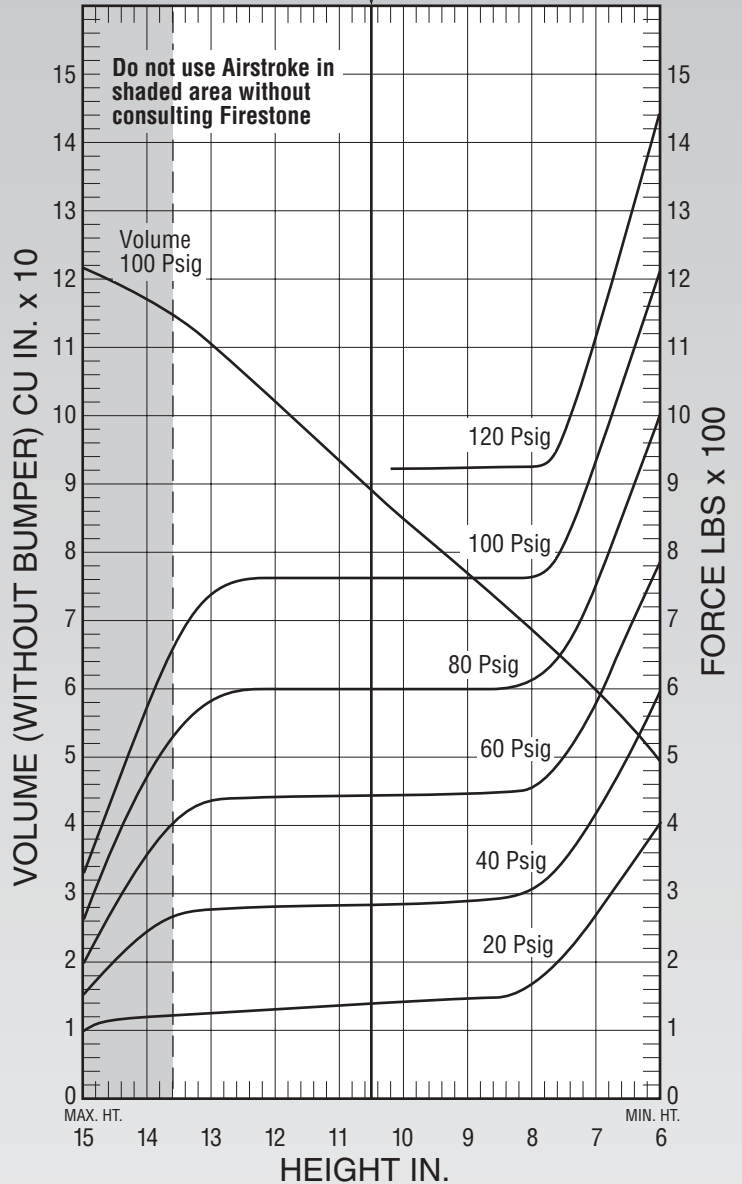

See page 12 for instructions on how to use chart.

Force Table (Use for Airstroke® actuator design)						
Assembly Height (in.)	Volume @ 100 PSIG (in ³)	Pounds Force				
		@20 PSIG	@40 PSIG	@60 PSIG	@80 PSIG	@100 PSIG
13.0	110	130	280	440	580	740
12.0	102	130	280	450	600	760
11.0	94	140	280	450	600	760
10.0	85	150	290	450	600	770
9.0	77	150	290	450	600	770
8.0	69	170	310	460	610	760
7.0	60	270	420	580	750	920