

1T15S-6 Firestone

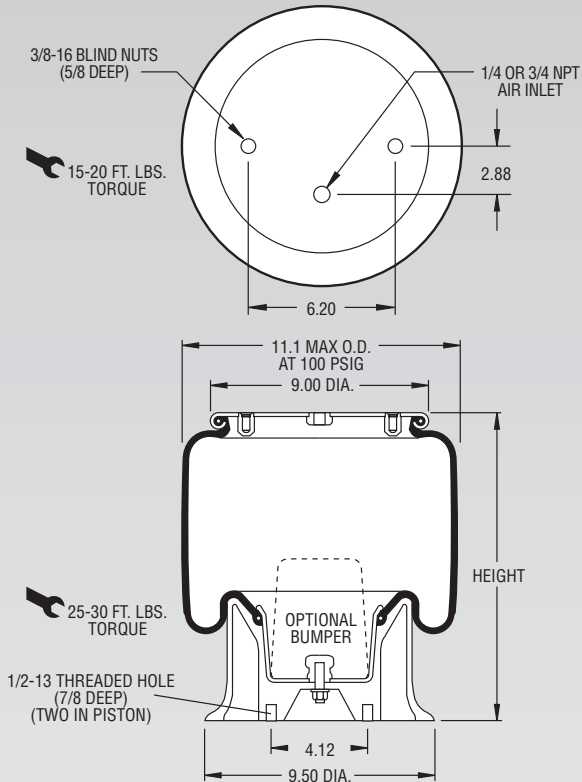

Description		Assembly Order No.
Style 1T15S-6	Blind nuts, 1/4 NPT	WO1-358-9048
	Blind nuts, 1/4 NPT, bumper	WO1-358-9049
Two Ply Bellows	Blind nuts, 3/4 NPT	WO1-358-9051
Assembly weight		13.7 lbs.



NOTE: Bellows will not compress properly with less than 20 PSIG internal pressure.

NOTE: A bead plate part is shown. This part is also available with a bead ring. Bolts are not included. See pages 8-10 for explanation.

Dynamic Characteristics at 12.0 in. Design Height (Required for Airmount isolator design only)				
Volume @ 100 PSIG = 625 in ³			Natural Frequency	
Gage Pressure (PSIG)	Load (lbs.)	Spring Rate (lbs./in.)	CPM	HZ
40	2,040	363	79	1.32
60	3,140	513	76	1.26
80	4,220	657	74	1.23
100	5,340	813	73	1.22

CONSULT FIRESTONE BEFORE USING AS AIRMOUNT

RECOMMENDED AIRMOUNT DESIGN HEIGHT 12.0 INCHES

Static Data
7597

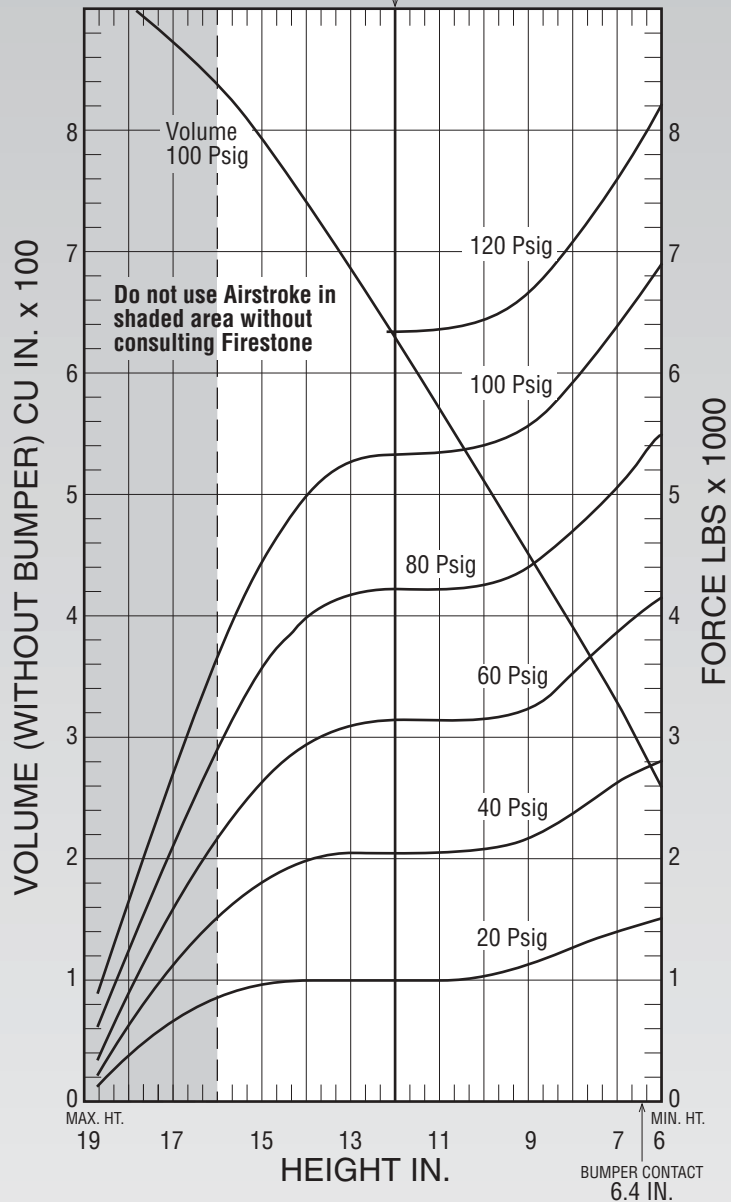

See page 12 for instructions on how to use chart.

Force Table (Use for Airstroke® actuator design)						
Assembly Height (in.)	Volume @ 100 PSIG (in ³)	Pounds Force				
		@20 PSIG	@40 PSIG	@60 PSIG	@80 PSIG	@100 PSIG
16.0	834	830	1,580	2,140	2,860	3,600
14.0	739	1,010	1,980	2,930	3,980	5,000
12.0	625	980	2,040	3,140	4,220	5,340
10.0	509	1,030	2,100	3,160	4,270	5,410
8.0	392	1,280	2,380	3,520	4,690	5,930