

Description		Assembly Order No.
Style 1T15T-1	Blind nuts, 1/4 NPT	WO1-358-9400
	Blind nuts, 1/4 NPT, bumper	WO1-358-9402
Two Ply Bellows	Blind nuts, 3/4 NPT	WO1-358-9401
Assembly weight		10.4 lbs.

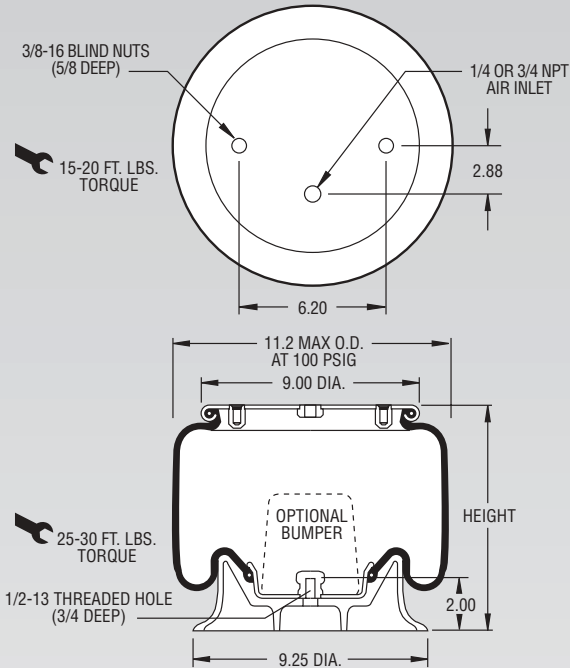

NOTE: Bellows will not compress properly with less than 10 PSIG internal pressure.

NOTE: A bead plate part is shown. This part is also available with a bead ring. Bolts are not included. See pages 8-10 for explanation..

CONSULT FIRESTONE BEFORE USING AS AIRMOUNT

RECOMMENDED AIRMOUNT DESIGN HEIGHT 7.0 INCHES

Static Data
4209

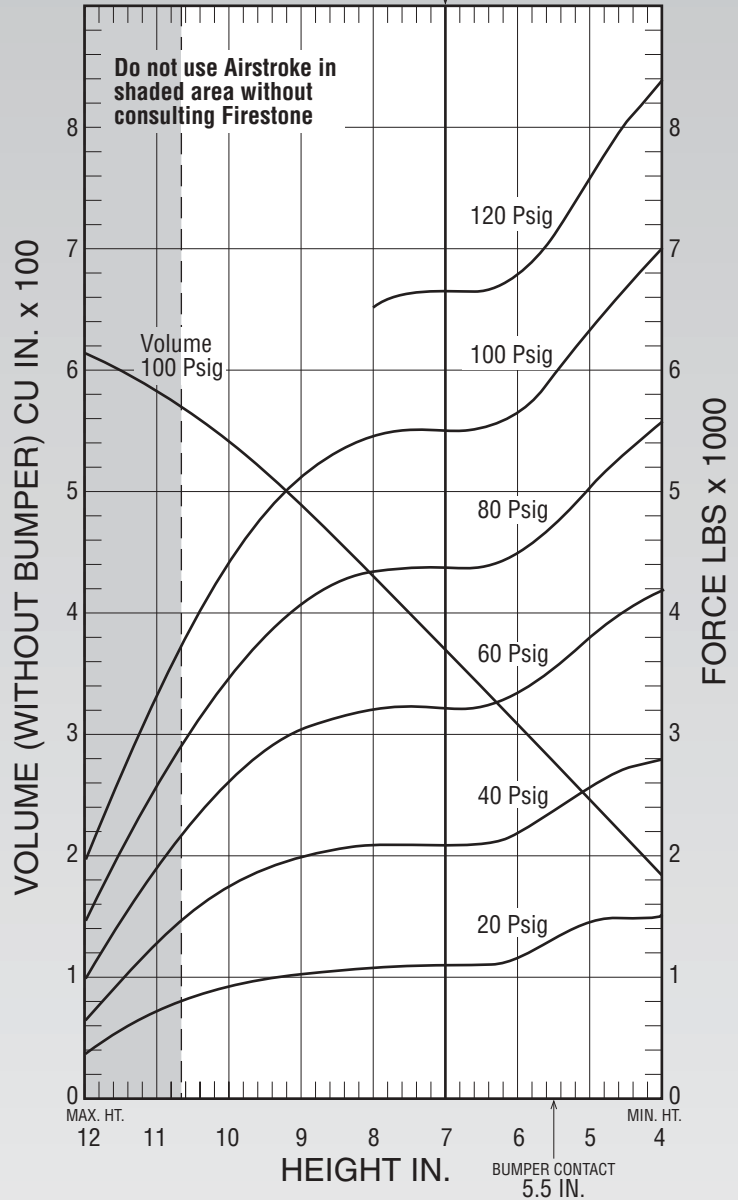

See page 12 for instructions on how to use chart.

Dynamic Characteristics at 7.0 in. Design Height (Required for Airmount isolator design only)				
Volume @ 100 PSIG = 373 in ³			Natural Frequency	
Gage Pressure (PSIG)	Load (lbs.)	Spring Rate (lbs./in.)	CPM	HZ
40	2,100	658	105	1.75
60	3,220	908	100	1.66
80	4,370	1,168	97	1.62
100	5,490	1,408	95	1.58

Force Table (Use for Airstroke® actuator design)						
Assembly Height (in.)	Volume @ 100 PSIG (in ³)	Pounds Force				
		@20 PSIG	@40 PSIG	@60 PSIG	@80 PSIG	@100 PSIG
10.0	541	920	1,750	2,600	3,470	4,410
9.0	490	1,030	2,010	3,050	4,050	5,130
8.0	433	1,100	2,090	3,210	4,330	5,470
7.0	373	1,110	2,100	3,220	4,370	5,490
6.0	314	1,160	2,190	3,330	4,480	5,650
5.0	251	1,450	2,570	3,780	5,010	6,290