

Description		Assembly Order No.
Style 1T19L-7	Blind nuts, 1/4 NPT	WO1-358-9148
	Blind nuts, 1/4 NPT, bumper	WO1-358-9149
Two Ply Bellows	Blind nuts, 3/4 NPT	WO1-358-9172
	Blind nuts, 3/4 NPT, bumper	WO1-358-9160
	Countersunk steel bead ring 1 3/4 bolts, nuts, washers	WO1-358-9165
Assembly weight		24.60 lbs.

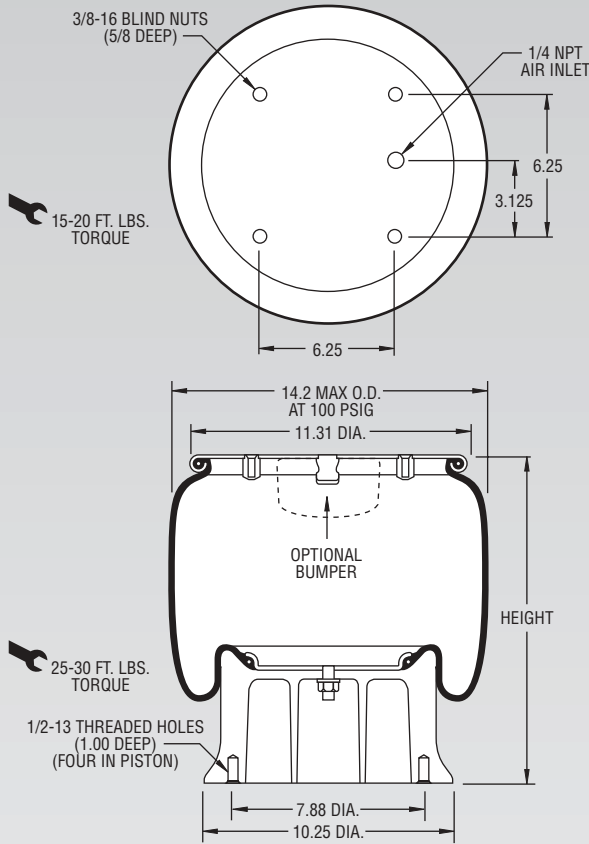

NOTE: Bellows will not compress properly with less than 20 PSIG internal pressure.

NOTE: A bead plate part is shown. This part is also available with a bead ring. Bolts are not included. See pages 8-10 for explanation.

Dynamic Characteristics at 15.0 in. Design Height (Required for Airmount isolator design only)				
Volume @ 100 PSIG = 1,252 in ³			Natural Frequency	
Gage Pressure (PSIG)	Load (lbs.)	Spring Rate (lbs./in.)	CPM	HZ
40	3,476	532	73	1.22
60	5,264	777	72	1.20
80	7,052	982	70	1.17
100	8,898	1,227	69	1.15

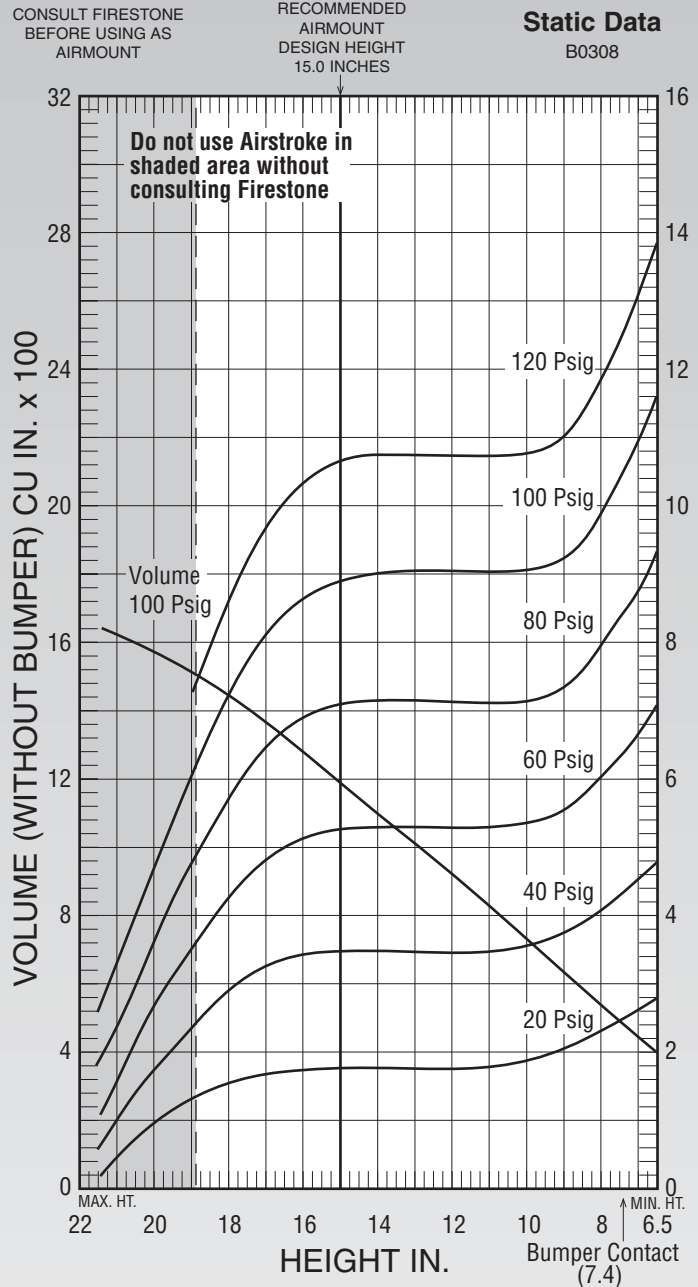

See page 12 for instructions on how to use chart.

Force Table (Use for Airstroke® actuator design)						
Assembly Height (in.)	Volume @ 100 PSIG (in ³)	Pounds Force				
		@20 PSIG	@40 PSIG	@60 PSIG	@80 PSIG	@100 PSIG
18.50	1,480	1,398	2,605	3,859	5,194	6,645
16.50	1,328	1,705	3,309	4,952	6,624	8,350
14.50	1,155	1,760	3,482	5,293	7,095	8,964
12.50	969	1,760	3,482	5,297	7,101	8,984
10.50	778	1,760	3,482	5,297	7,101	8,984
8.50	591	2,126	3,876	5,748	7,597	9,515