

Description		Assembly Order No.
Style 22-1.5	Blind nuts, 1/4 NPT	WO1-358-7444
	Blind nuts, 1/4 NPT, rubber bumper	WO1-358-7473
Two Ply Bellows	Blind nuts, 3/4 NPT	WO1-358-7442
	Blind nuts, 1/4 NPT(centered)	WO1-358-7443
	Rubber bellows only	WO1-358-0259
Assembly weight		12.9 lbs.
Force to collapse to minimum height (@ 0 PSIG).....		26 lbs.

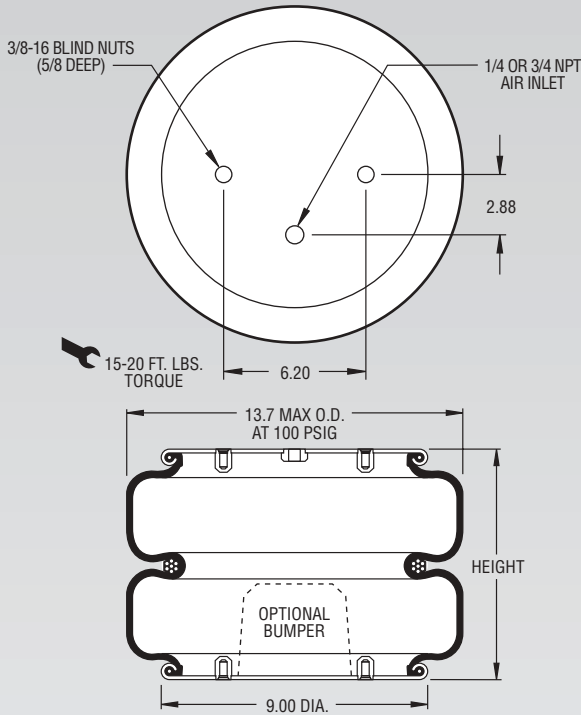

NOTE: The bellows extends beyond the bead plates at minimum height.

NOTE: A bead plate part is shown. This part is also available with bead rings. See pages 8-10 for explanation.

Dynamic Characteristics at 10.5 in. Design Height (Required for Airmount isolator design only)				
Volume @ 100 PSIG = 935 in ³			Natural Frequency	
Gage Pressure (PSIG)	Load (lbs.)	Spring Rate (lbs./in.)	CPM	HZ
40	1,930	684	112	1.86
60	3,030	999	108	1.80
80	4,130	1,319	106	1.77
100	5,310	1,630	104	1.73

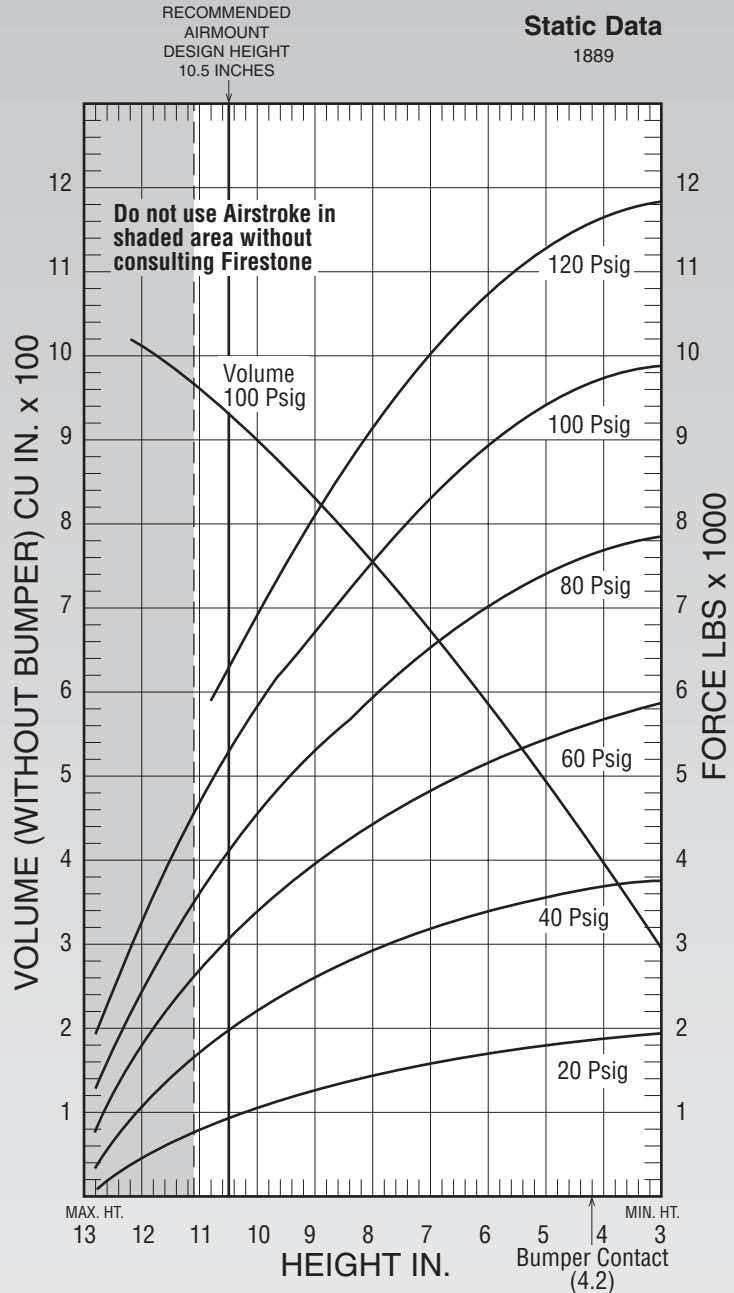

See page 12 for instructions on how to use chart.

Force Table (Use for Airstroke® actuator design)						
Assembly Height (in.)	Volume @ 100 PSIG (in ³)	Pounds Force				
		@20 PSIG	@40 PSIG	@60 PSIG	@80 PSIG	@100 PSIG
10.0	905	1,040	2,140	3,340	4,550	5,830
9.0	838	1,220	2,520	3,880	5,250	6,700
8.0	763	1,370	2,850	4,360	5,850	7,450
7.0	681	1,510	3,150	4,810	6,430	8,170
6.0	591	1,650	3,400	5,210	6,990	8,860
5.0	496	1,760	3,590	5,520	7,420	9,380
4.0	396	1,840	3,730	5,730	7,680	9,700