

Description		Assembly Order No.
Style 233-2	Blind nuts, 1/4 NPT	WO1-358-6810
Two Ply Bellows	Blind nuts, 1/4 NPT, rubber bumper	WO1-358-7781
	Blind nuts, 3/4 NPT	WO1-358-6811
	Blind nuts, 3/4 NPT, rubber bumper	WO1-358-6819
Assembly weight		19.6 lbs
Force to collapse to minimum height (@ 0 PSIG)....		100 lbs.

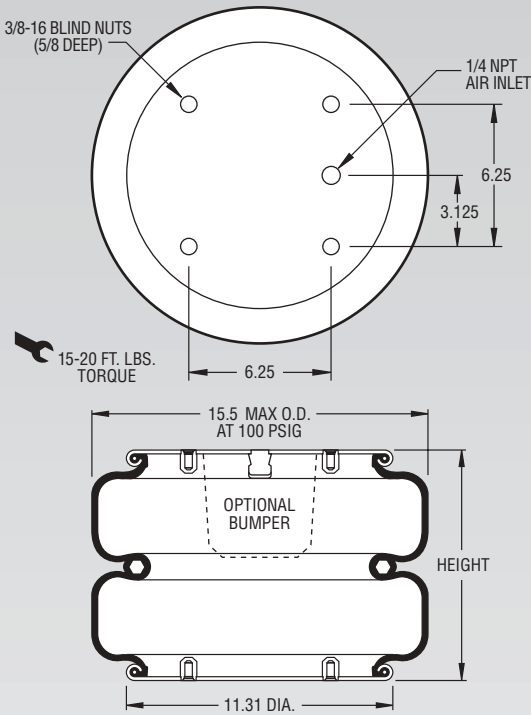

NOTE: The bellows extends beyond the bead plates at minimum height.

NOTE: A bead plate part is shown. This part is also available with bead rings. See pages 8-10 for explanation.

Dynamic Characteristics at 11.25 in. Design Height (Required for Airmount isolator design only)				
Volume @ 100 PSIG = 1,418 in ³			Natural Frequency	
Gage Pressure (PSIG)	Load (lbs.)	Spring Rate (lbs./in.)	CPM	HZ
40	3,413	968	100	1.67
60	5,631	1,351	92	1.53
80	7,691	1,735	89	1.49
100	9,917	2,122	87	1.45

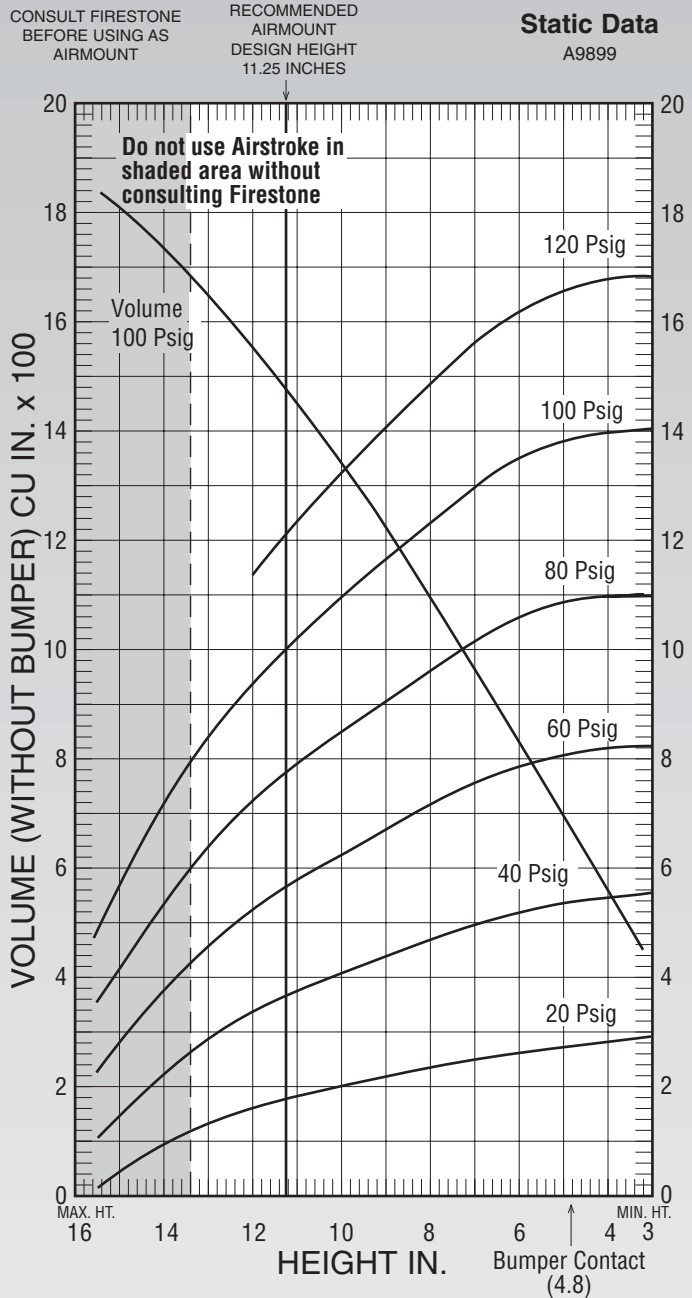

See page 12 for instructions on how to use chart.

Force Table (Use for Airstroke [®] actuator design)						
Assembly Height (in.)	Volume @ 100 PSIG (in ³)	Pounds Force				
		@20 PSIG	@40 PSIG	@60 PSIG	@80 PSIG	@100 PSIG
12.0	1,548	1,542	3,299	5,184	7,194	9,321
10.0	1,333	1,992	4,052	6,239	8,483	10,937
8.0	1,091	2,311	4,666	7,128	9,601	12,333
6.0	829	2,569	5,174	7,485	10,564	13,468
4.0	556	2,793	5,431	8,189	10,966	13,867