

Description		Assembly Order No.
Style 25	Blind nuts, 1/4 NPT	WO1-358-7025
	Blind nuts, 3/4 NPT	WO1-358-7047
Two Ply Bellows	Blind nuts, 1/4 NPT both ends 3/4 NPT both ends (no blind nuts)	WO1-358-7035
	Socket head aluminum bead rings (bolts, nuts, washers not included, use cap screws)	WO1-606-7025
	3/4 NPT (only) upper plate, blind nuts lower plate	WO1-358-0030
	3/4 NPT (only) upper plate, blind nuts lower plate	WO1-358-7030
	Rubber bellows only	WO1-358-0319
Assembly weight .....		3.8 lbs.
Force to collapse to minimum height (@ 0 PSIG).....		30 lbs.

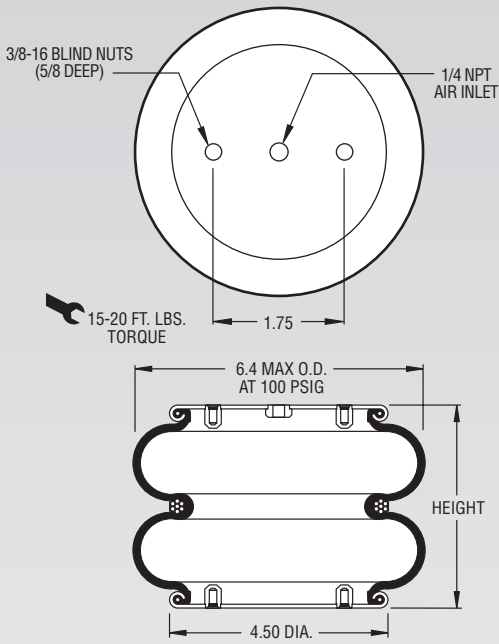

**NOTE: A bead plate part is shown. This part is also available with bead rings. Bolts are not included. See pages 8-10 for explanation.**

Dynamic Characteristics at 5.5 in. Design Height (Required for Airmount isolator design only)				
Volume @ 100 PSIG = 82 in <sup>3</sup>			Natural Frequency	
Gage Pressure (PSIG)	Load (lbs.)	Spring Rate (lbs./in.)	CPM	HZ
40	430	329	164	2.73
60	670	477	158	2.63
80	910	616	154	2.57
100	1,180	757	151	2.51

RECOMMENDED AIRMOUNT DESIGN HEIGHT 5.5 INCHES

**Static Data**  
8828

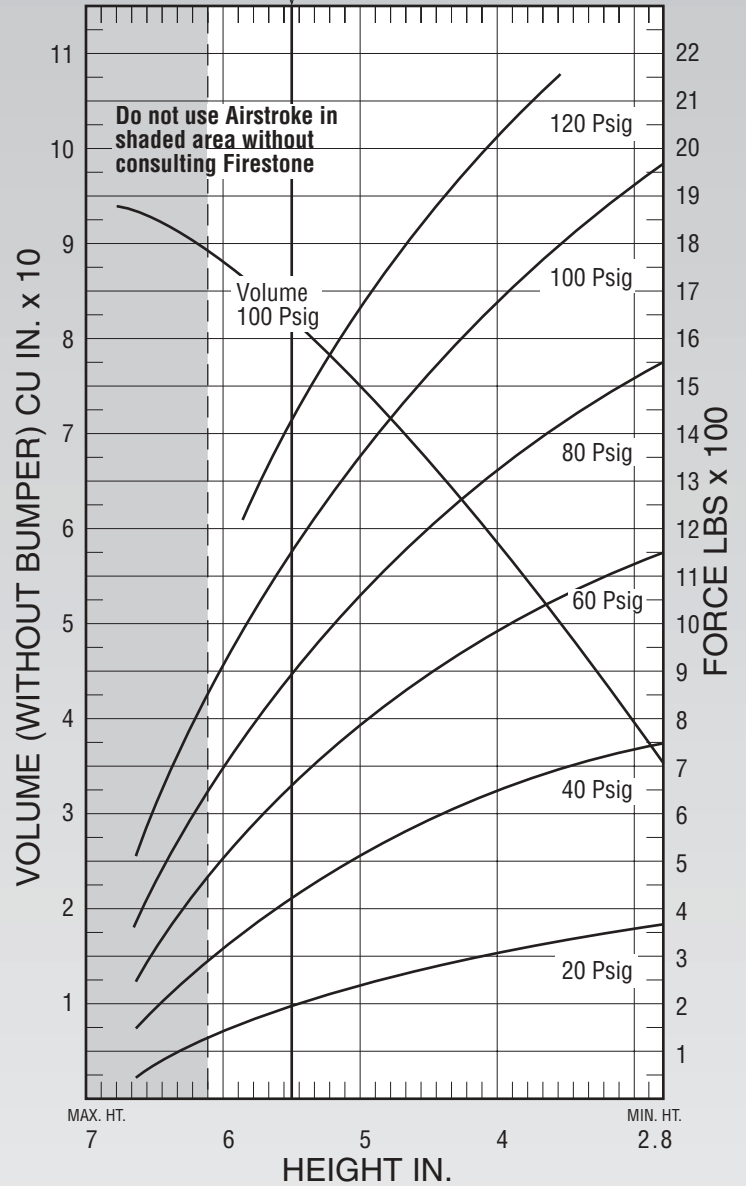

See page 12 for instructions on how to use chart.

Force Table (Use for Airstroke <sup>®</sup> actuator design)						
Assembly Height (in.)	Volume @ 100 PSIG (in <sup>3</sup> )	Pounds Force				
		@20 PSIG	@40 PSIG	@60 PSIG	@80 PSIG	@100 PSIG
5.0	75	240	520	800	1,080	1,380
4.0	58	310	660	990	1,330	1,690
3.0	39	360	750	1,130	1,530	1,930