

Description		Assembly Order No.
Style 26	Blind nuts, 1/4 NPT	WO1-358-7325
	Blind nuts, 3/4 NPT	WO1-358-7327
Two Ply Bellows	Countersunk steel bead rings, 1 3/4 bolts, nuts, washers	WO1-358-7333
	Rubber bellows only	WO1-358-0142
Assembly weight		5.3 lbs.
Force to collapse to minimum height (@ 0 PSIG).....		23 lbs.

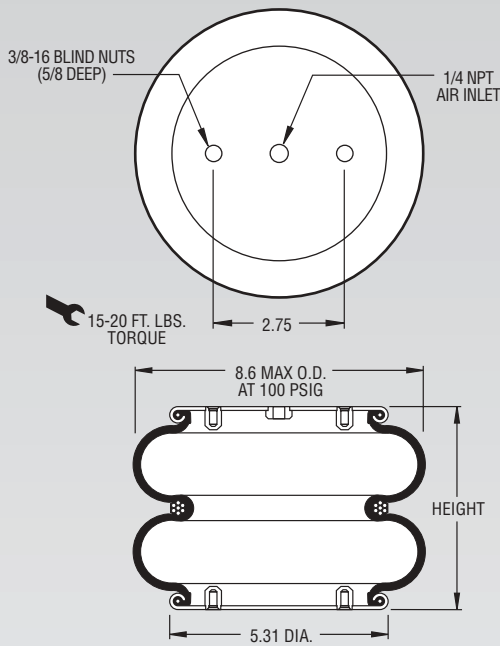

NOTE: A bead plate part is shown. This part is also available with bead rings. See pages 8-10 for explanation.

Dynamic Characteristics at 8.0 in. Design Height (Required for Airmount isolator design only)				
Volume @ 100 PSIG = 241 in ³			Natural Frequency	
Gage Pressure (PSIG)	Load (lbs.)	Spring Rate (lbs./in.)	CPM	HZ
40	790	322	120	1.99
60	1,230	454	114	1.90
80	1,670	589	111	1.85
100	2,140	720	109	1.82

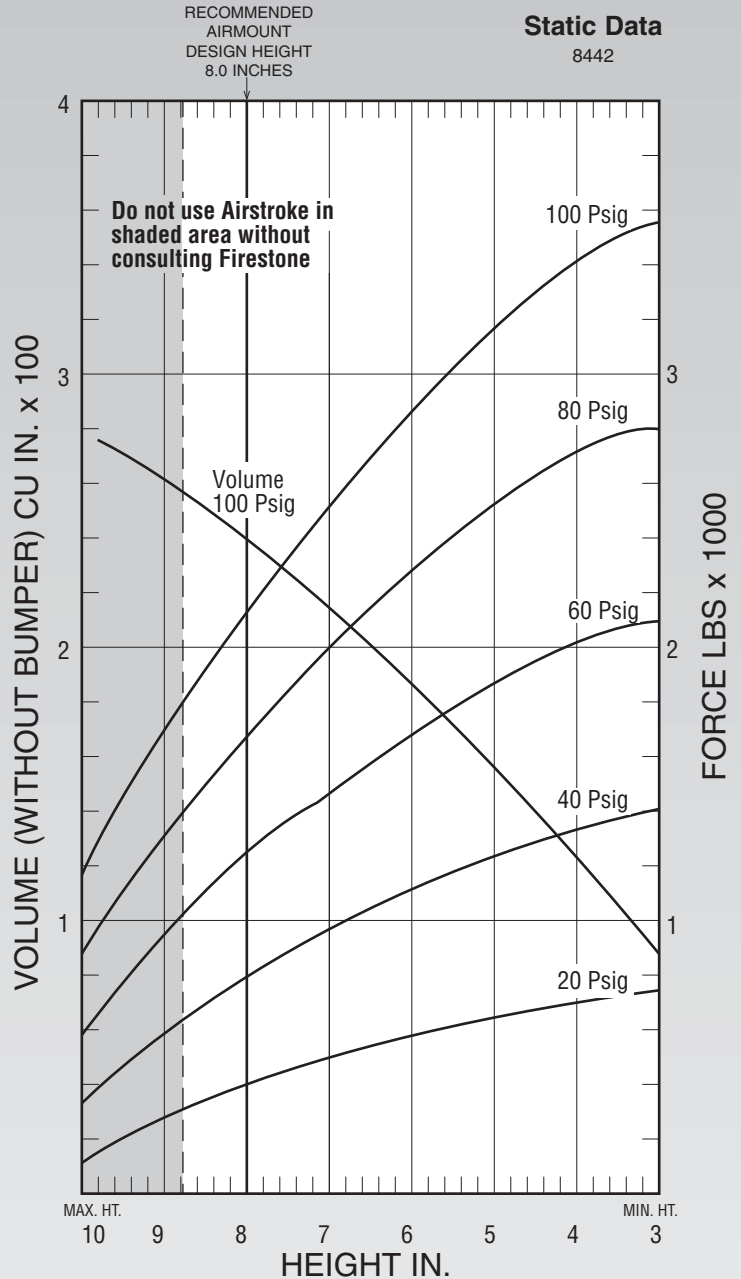

See page 12 for instructions on how to use chart.

Force Table (Use for Airstroke® actuator design)						
Assembly Height (in.)	Volume @ 100 PSIG (in ³)	Pounds Force				
		@20 PSIG	@40 PSIG	@60 PSIG	@80 PSIG	@100 PSIG
8.0	241	400	790	1,230	1,670	2,140
7.0	217	490	950	1,460	1,970	2,500
6.0	189	570	1,090	1,660	2,230	2,820
5.0	158	640	1,220	1,850	2,490	3,140
4.0	124	690	1,340	2,010	2,700	3,400