

Description		Assembly Order No.
Style 313	Blind nuts, 1/4 NPT	WO1-358-7808
	Blind nuts, 1/4 NPT, bumper	WO1-358-7811
Two Ply Bellows	Blind nuts, 3/4 NPT	WO1-358-7802
	Blind nuts, 3/4 NPT, bumper	WO1-358-7807
	Countersunk steel bead rings, 1 <sup>3</sup> / <sub>4</sub> bolts, nuts, washers	WO1-358-7801
	Rubber bellows only	WO1-358-7900
Assembly weight .....		19.5 lbs
Force to collapse to minimum height (@ 0 PSIG).....		46 lbs.

Style 39	Blind nuts, 1/4 NPT	WO1-358-1098
	Blind nuts, 3/4 NPT	WO1-358-7815
High Strength Bellows	Countersunk steel bead rings, 1 <sup>3</sup> / <sub>4</sub> bolts, nuts, washers	WO1-358-1099

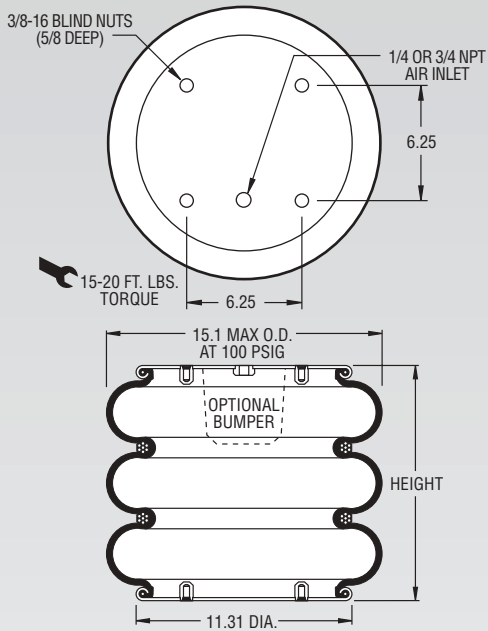

**NOTE: A bead plate part is shown. This part is also available with bead rings. See pages 8-10 for explanation.**

Dynamic Characteristics at 13.0 in. Design Height (Required for Airmount isolator design only)				
Volume @ 100 PSIG = 1,585 in <sup>3</sup>			Natural Frequency	
Gage Pressure (PSIG)	Load (lbs.)	Spring Rate (lbs./in.)	CPM	HZ
40	3,310	716	87	1.45
60	5,120	1,049	85	1.41
80	7,020	1,348	82	1.37
100	8,960	1,668	81	1.35

CONSULT FIRESTONE BEFORE USING AS AIRMOUNT

RECOMMENDED AIRMOUNT DESIGN HEIGHT 13.0 INCHES

**Static Data**  
1841

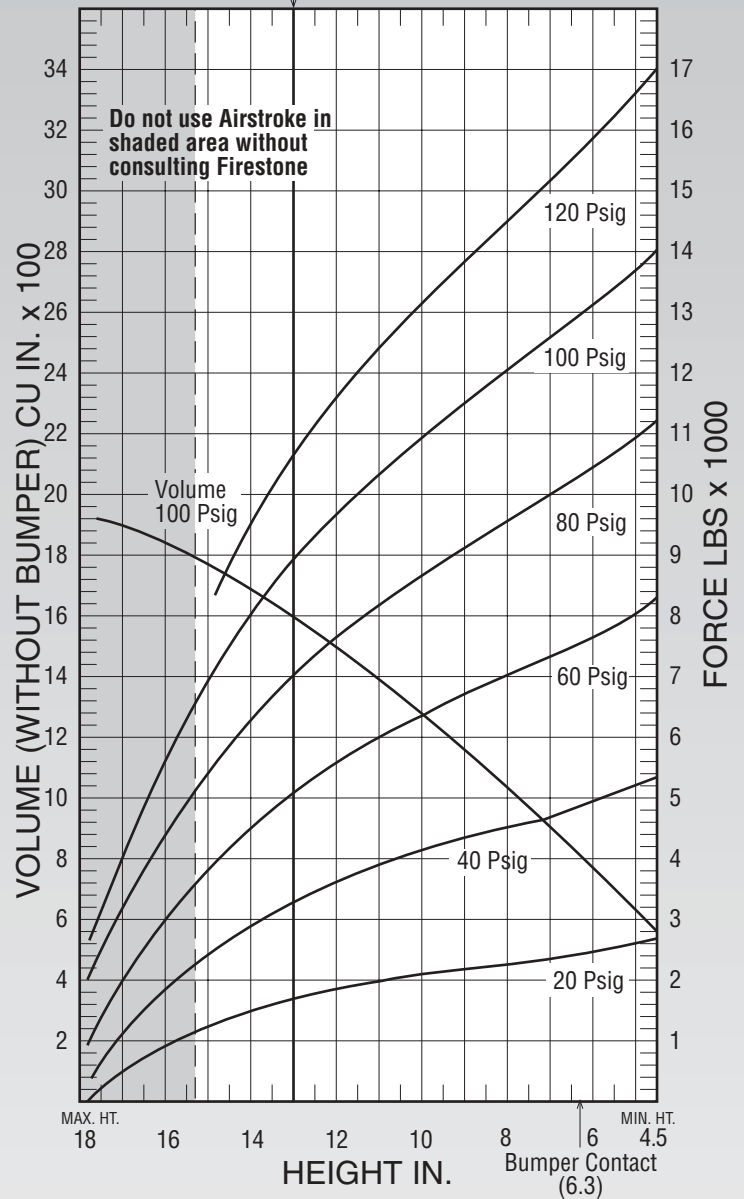

See page 12 for instructions on how to use chart.

Force Table (Use for Airstroke <sup>®</sup> actuator design)						
Assembly Height (in.)	Volume @ 100 PSIG (in <sup>3</sup> )	Pounds Force				
		@20 PSIG	@40 PSIG	@60 PSIG	@80 PSIG	@100 PSIG
15.0	1,760	1,280	2,500	3,870	5,470	7,040
13.0	1,585	1,710	3,310	5,120	7,020	8,960
11.0	1,379	1,970	3,920	6,030	8,200	10,360
9.0	1,149	2,140	4,340	6,710	9,120	11,480
7.0	898	2,350	4,730	7,290	9,920	12,510
5.0	625	2,640	5,230	8,050	10,940	13,670