

Description		Assembly Order No.
Style 321	Ribbed neck aluminum bead rings (equal spacing), 1 7/8 bolts, nuts, washers	WO1-358-7304
Two Ply High Strength Bellows	Ribbed neck aluminum bead rings (unequal spacing) 1 7/8 b,n,w	WO1-358-7306
	Rubber bellows only	WO1-358-7919
Assembly weight.....		103.9 lbs
Force to collapse to minimum height (@ 0 PSIG)....		380 lbs.

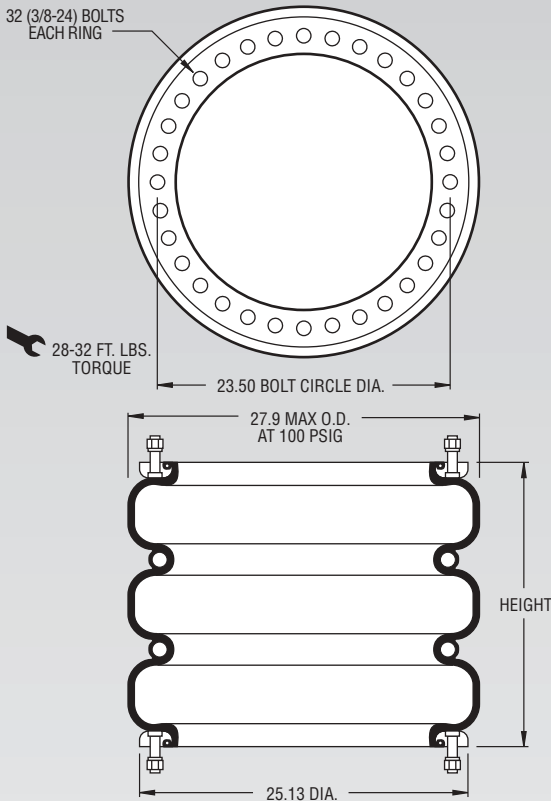

CONSULT FIRESTONE BEFORE USING AS AIRMOUNT

RECOMMENDED AIRMOUNT DESIGN HEIGHT 15.0 INCHES

Static Data
1229

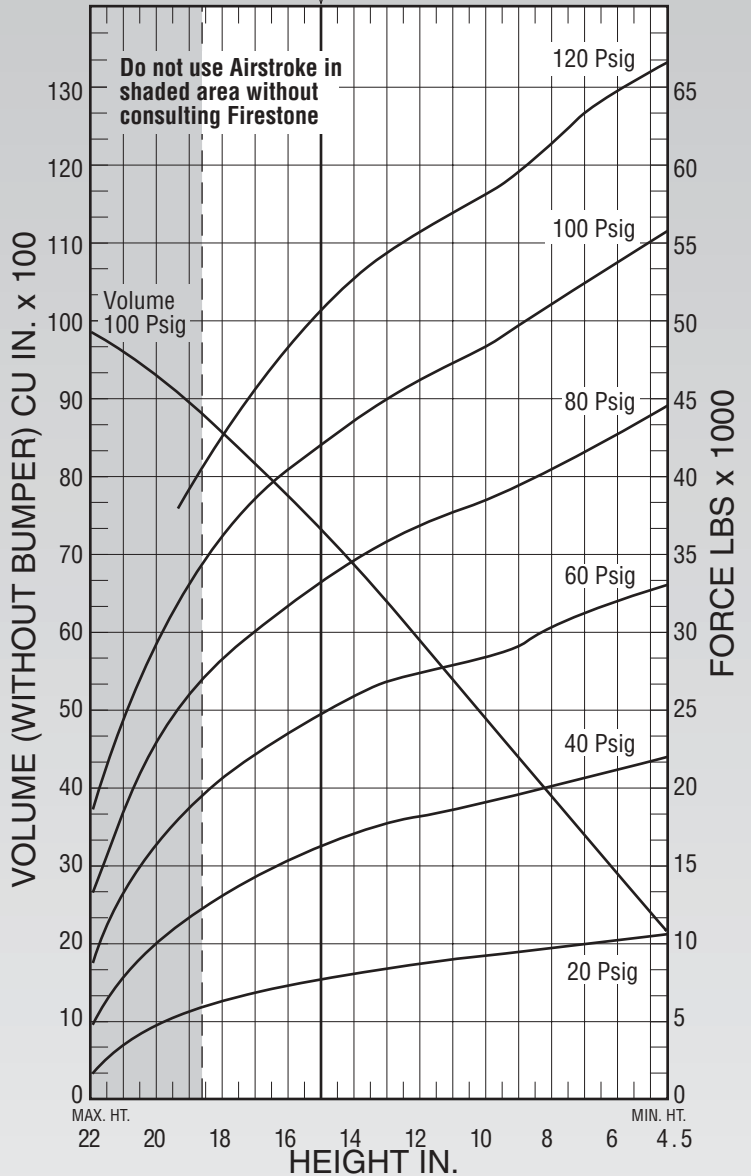

See page 12 for instructions on how to use chart.

Dynamic Characteristics at 15.0 in. Design Height (Required for Airmount isolator design only)				
Volume @ 100 PSIG = 7,346 in ³			Natural Frequency	
Gage Pressure (PSIG)	Load (lbs.)	Spring Rate (lbs./in.)	CPM	HZ
40	16,220	2,538	74	1.24
60	24,690	3,623	72	1.20
80	33,290	4,624	70	1.17
100	41,900	5,620	69	1.15

Force Table (Use for Airstroke® actuator design)						
Assembly Height (in.)	Volume @ 100 PSIG (in ³)	Pounds Force				
		@20 PSIG	@40 PSIG	@60 PSIG	@80 PSIG	@100 PSIG
18.0	8,561	6,400	13,320	20,620	28,020	35,660
16.0	7,770	7,510	15,410	23,490	31,760	40,060
14.0	6,904	8,200	16,890	25,740	34,610	43,510
12.0	5,983	8,710	17,960	27,350	36,690	46,120
10.0	5,019	9,240	18,830	28,410	38,280	48,150
8.0	4,007	9,790	19,850	30,160	40,510	50,860
6.0	2,944	10,260	20,990	32,110	42,880	53,710