

Description		Assembly Order No.
Style 323	Ribbed neck aluminum bead rings (equal spacing), 1 7/8 bolts, nuts, washers	WO1-358-7823
Two Ply Bellows	Rubber bellows only	WO1-358-7274
	Rubber bellows only	WO1-358-7921
Assembly weight		31.1 lbs
Force to collapse to minimum height (@ 0 PSIG).....		70 lbs.

Style 324	Ribbed neck aluminum bead rings (equal spacing), 1 7/8 bolts, nuts, washers	WO1-358-7829
High Strength Bellows	Rubber bellows only	WO1-358-0324

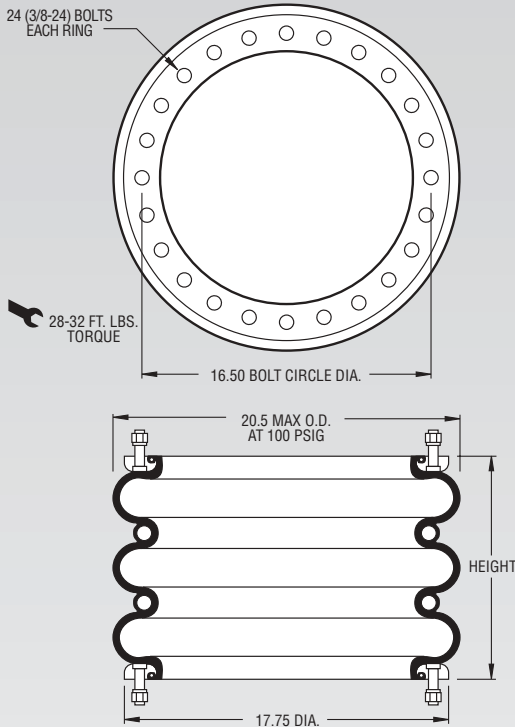

NOTE: A bead ring part is shown. This part is also available with rolled plates. See page 11 for explanation.

Dynamic Characteristics at 13.0 in. Design Height (Required for Airmount isolator design only)				
Volume @ 100 PSIG = 3,109 in ³			Natural Frequency	
Gage Pressure (PSIG)	Load (lbs.)	Spring Rate (lbs./in.)	CPM	HZ
40	7,380	1,487	84	1.40
60	11,520	2,080	80	1.33
80	15,550	2,652	77	1.29
100	19,660	3,399	78	1.30

CONSULT FIRESTONE BEFORE USING AS AIRMOUNT

RECOMMENDED AIRMOUNT DESIGN HEIGHT 13.0 INCHES

Static Data
1808

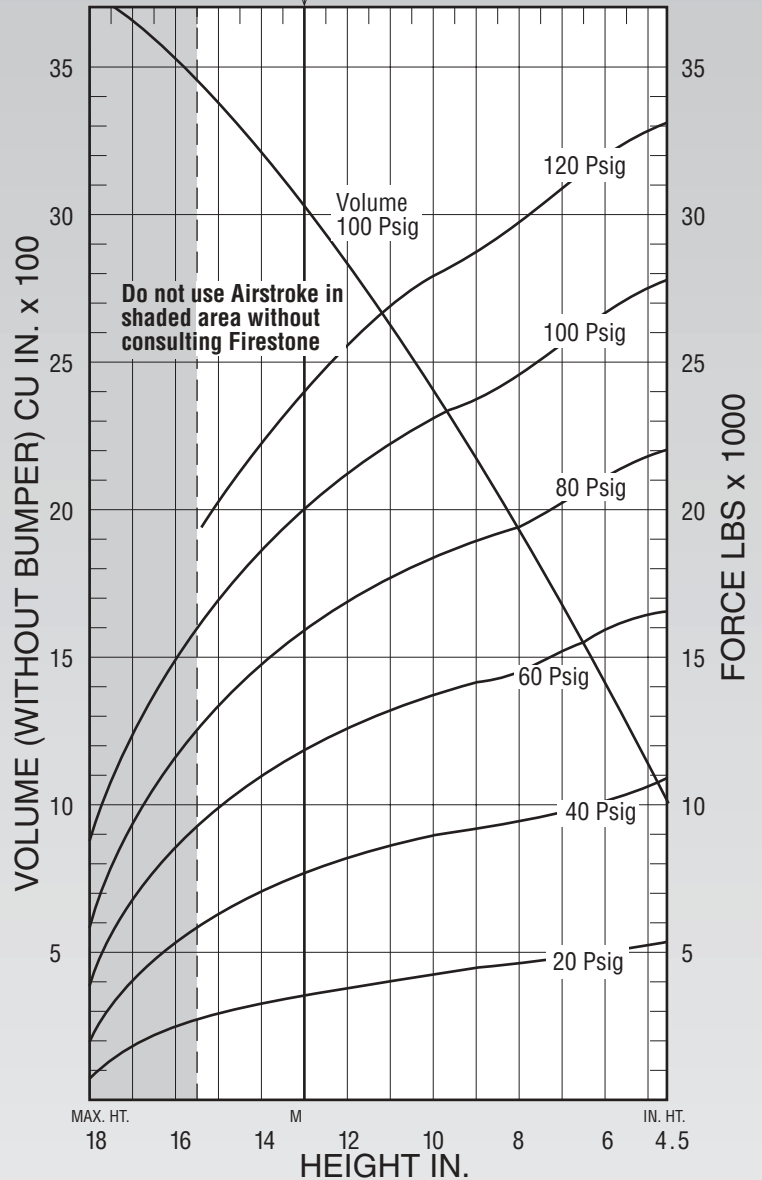

See page 12 for instructions on how to use chart.

Force Table (Use for Airstroke® actuator design)						
Assembly Height (in.)	Volume @ 100 PSIG (in ³)	Pounds Force				
		@20 PSIG	@40 PSIG	@60 PSIG	@80 PSIG	@100 PSIG
15.0	3,496	2,940	6,160	9,810	13,170	16,620
13.0	3,109	3,490	7,380	11,520	15,550	19,660
11.0	2,673	3,970	8,400	12,910	17,270	21,910
9.0	2,201	4,330	9,150	13,890	18,650	23,500
7.0	1,698	4,670	9,660	14,850	19,890	25,140
5.0	1,155	5,160	10,360	16,050	21,470	26,970