

Description		Assembly Order No.
Style 333	Blind nuts, 1/4 NPT	WO1-358-7845
	Blind nuts, 1/4 NPT, bumper	WO1-358-7838
Two Ply Bellows	Blind nuts, 3/4 NPT	WO1-358-7842
	Blind nuts, 3/4 NPT, bumper	WO1-358-7849
	Countersunk steel bead ring	
	1 ³ / ₄ bolts, nuts, washers	WO1-358-7830
	Rubber bellows only	WO1-358-7019
Assembly weight		24.6 lbs.
Force to collapse to minimum height (@ 0 PSIG).....		65 lbs.

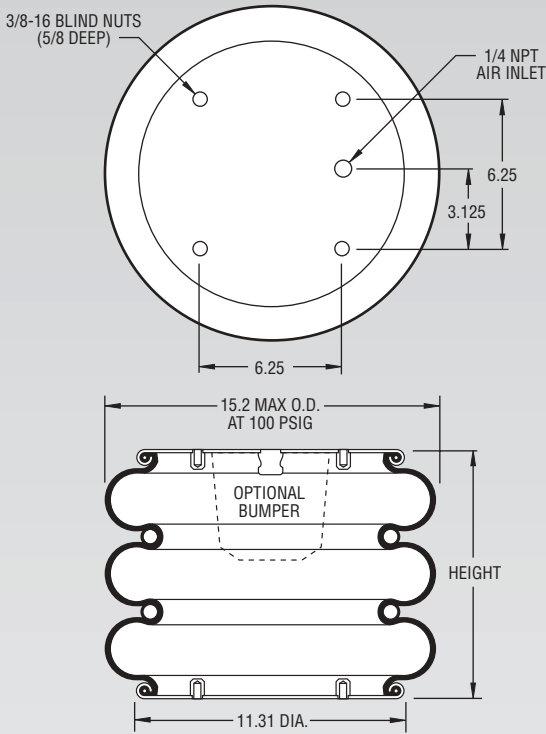

NOTE: A bead plate part is shown. This part is also available with bead rings. See pages 8-10 for explanation.

Dynamic Characteristics at 14.70 in. Design Height (Required for Airmount isolator design only)				
Volume @ 100 PSIG = 1,786 in ³			Natural Frequency	
Gage Pressure (PSIG)	Load (lbs.)	Spring Rate (lbs./in.)	CPM	HZ
40	3,282	685	86	1.43
60	5,167	933	80	1.33
80	7,000	1,179	77	1.28
100	8,940	1,425	75	1.25

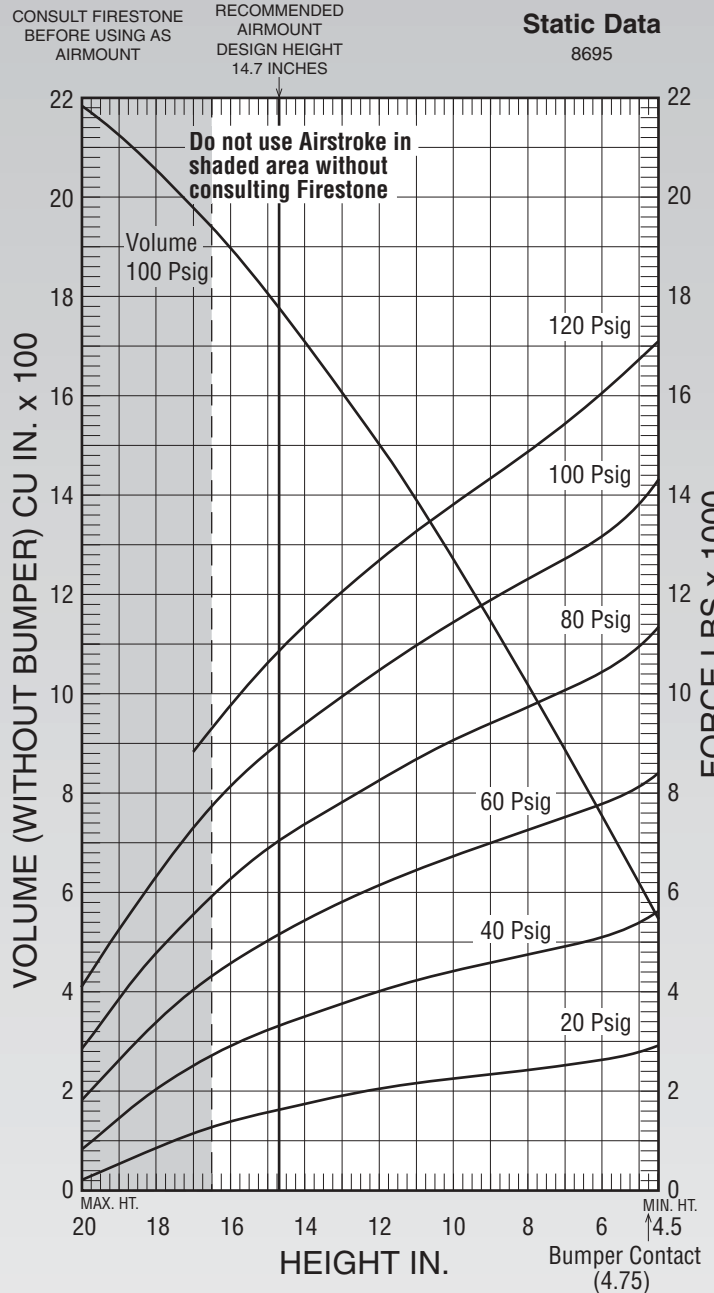

See page 12 for instructions on how to use chart.

Force Table (Use for Airstroke® actuator design)						
Assembly Height (in.)	Volume @ 100 PSIG (in ³)	Pounds Force				
		@20 PSIG	@40 PSIG	@60 PSIG	@80 PSIG	@100 PSIG
16.0	1,904	1,338	2,866	4,524	6,241	8,062
14.0	1,718	1,706	3,478	5,388	7,325	9,338
12.0	1,507	1,981	3,955	6,083	8,200	10,405
10.0	1,274	2,208	4,376	6,698	9,003	11,400
8.0	1,022	2,389	4,733	7,220	9,710	12,278
6.0	754	2,574	5,087	7,724	10,396	13,139
4.0	473	3,049	5,871	8,787	11,827	14,918