

Description		Assembly Order No.
Style 348-3	Ribbed neck aluminum bead rings (equal spacing), 1 7/8 bolts, nuts, washers	WO1-358-9603
High Strength Bellows	Rubber bellows only	WO1-358-1023
Assembly weight		103.9 lbs
Force to collapse to minimum height (@ 0 PSIG)....		380 lbs.

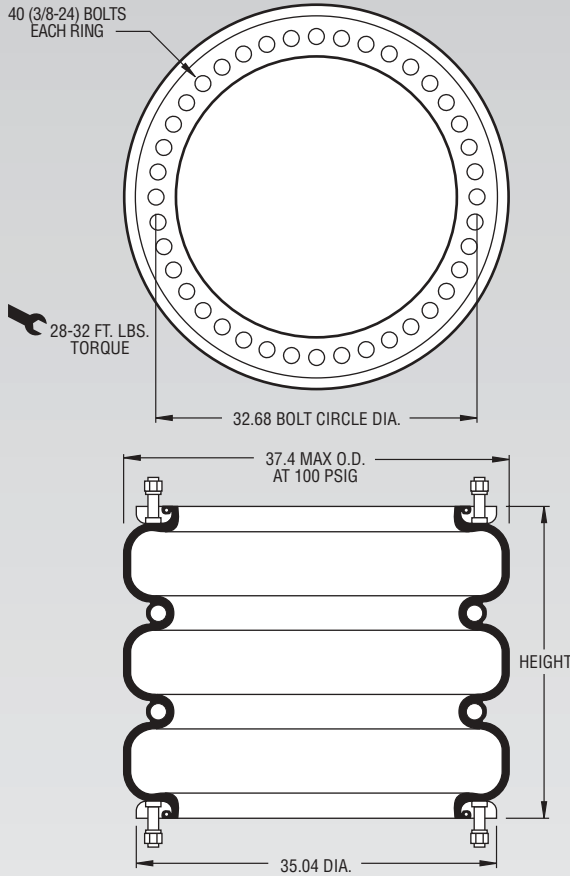

NOTE: The effective length of the 1 7/8 bolt is 1.05" in this bead ring.

Dynamic Characteristics at 15.0 in. Design Height (Required for Airmount isolator design only)				
Volume @ 100 PSIG = 13,501 in ³			Natural Frequency	
Gage Pressure (PSIG)	Load (lbs.)	Spring Rate (lbs./in.)	CPM	HZ
40	31,480	4,761	73	1.22
60	47,870	6,586	70	1.16
80	64,870	8,614	68	1.14
100	82,540	10,592	67	1.12

CONSULT FIRESTONE BEFORE USING AS AIRMOUNT

RECOMMENDED AIRMOUNT DESIGN HEIGHT 15.0 INCHES

Static Data
8413

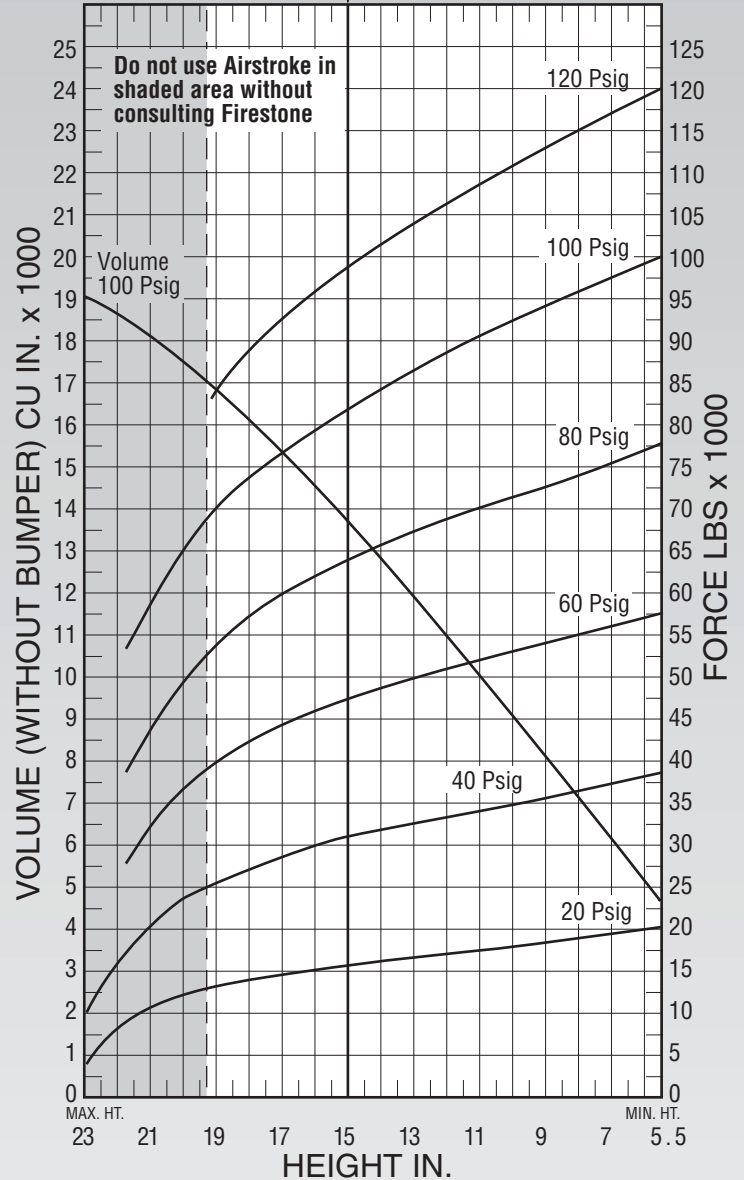

See page 12 for instructions on how to use chart.

Force Table (Use for Airstroke [®] actuator design)						
Assembly Height (in.)	Volume @ 100 PSIG (in ³)	Pounds Force				
		@20 PSIG	@40 PSIG	@60 PSIG	@80 PSIG	@100 PSIG
18.0	15,946	14,080	27,430	43,790	57,710	74,670
16.0	14,340	15,190	30,370	46,420	62,810	80,190
14.0	12,634	16,230	32,380	49,170	66,610	84,820
12.0	10,843	17,330	33,880	51,470	69,410	89,150
10.0	8,984	18,290	35,370	53,580	71,930	93,030
8.0	7,075	19,070	36,970	55,590	74,740	96,470
6.0	5,102	19,760	38,620	57,550	77,790	99,680