

NOTE: All Assembly Order Numbers are for bead plate parts unless noted otherwise.

	Description	Assembly Order No.
Style 116	Blind nuts, 1/4 BSP	W01-M58-6166
	Blind nuts, 3/4 BSP	W01-M58-6165
Two Ply Bellows	Countersunk steel bead rings, 40 mm bolts, nuts & washers	SEE NOTE BELOW
	Rubber bellows only	W01-358-0133
Assembly weight.....		1.95 kg.
Force to collapse to minimum height (@ 0 BAR)		36 N.

	Description	Assembly Order No.
Style 117	Blind nuts, 1/4 BSP	W01-M58-6176
	Blind nuts, 3/4 BSP	W01-M58-6175
High Strength Construction	Countersunk steel bead rings, 40 mm bolts, nuts & washers	SEE NOTE BELOW

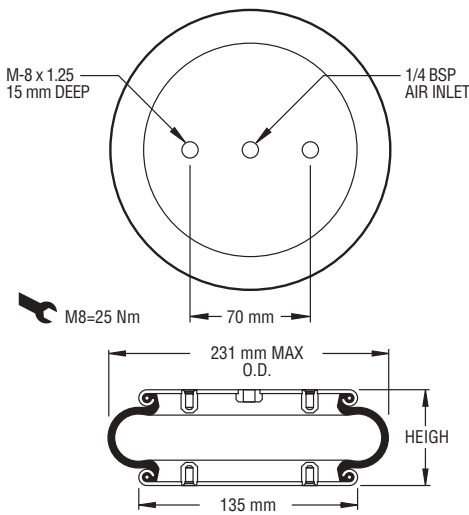

NOTE: A bead plate part is shown. This part is also available with bead rings. See pages 8-10 for explanation.

Gauge Pressure (BAR)	Load (kN)	Spring Rate (kN/m)	Natural Frequency Hz
3	4.16	132	2.80
4	5.73	169	2.71
5	7.26	207	2.67
6	8.98	247	2.62
7	10.55	285	2.59

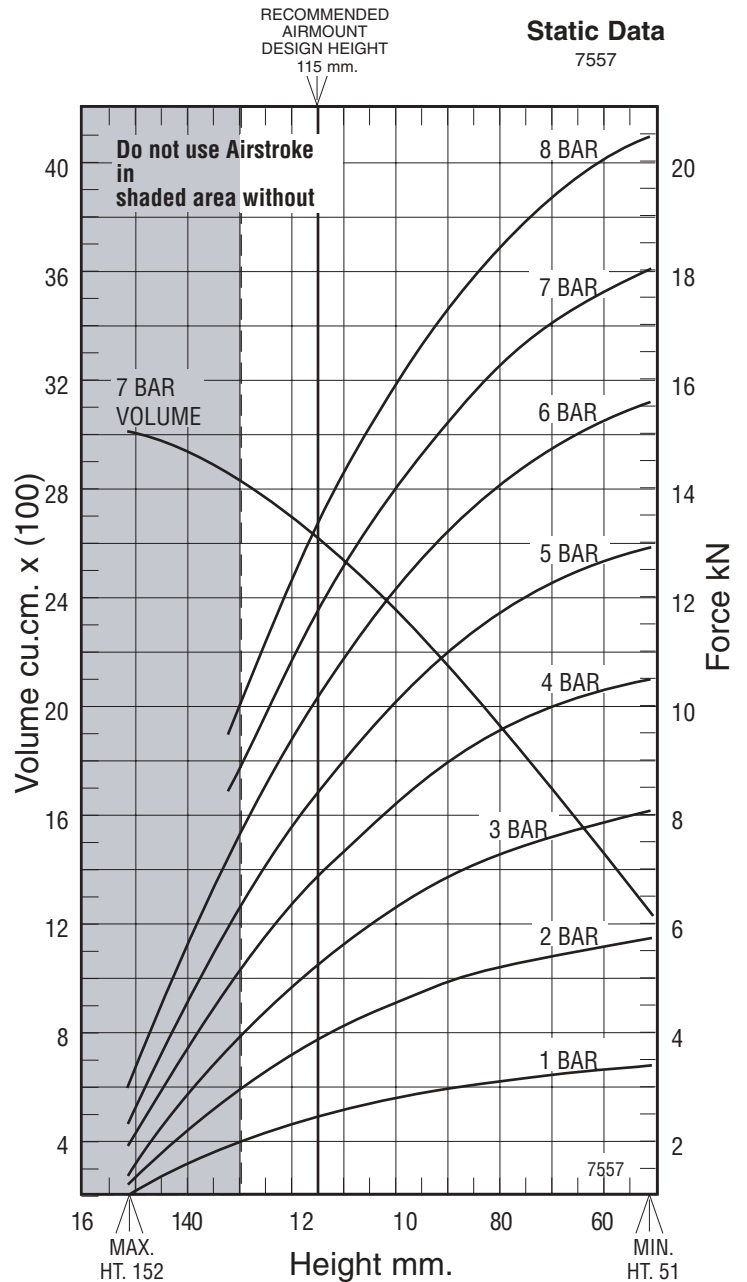

See page 12 for instructions on how to use chart.

Assembly Height (mm)	Volume @ 7 BAR (cu cm)	EFF Area @ 7 BAR (cm ²)	kN Force				
			@ 3 BAR	@ 4 BAR	@ 5 BAR	@ 6 BAR	@ 7 BAR
130	2635	110	2.86	4.04	5.17	6.51	7.71
120	2506	138	3.75	5.20	6.60	8.20	9.65
110	2341	163	4.54	6.22	7.86	9.70	11.38
100	2164	183	5.20	7.07	8.92	10.95	12.82
90	1956	201	5.75	7.84	9.84	12.04	14.07
80	1745	215	6.19	8.45	10.59	12.91	15.08
70	1509	228	6.54	8.91	11.18	13.64	15.92
60	1280	236	6.82	9.20	11.58	14.17	16.55