

NOTE: All Assembly Order Numbers are for bead ring parts unless noted otherwise.

| | Description | Assembly Order No. |
|---|---|--------------------|
| Style 119 | Ribbed neck aluminum bead rings (equal spacing), 45 mm bolts, nuts, washers | W01-M58-6974 |
| Two Ply Bellows | Rubber bellows only | W01-358-0119 |
| | Rolled plate assembly, 1/2 blind nuts, 3/4 BSP | SEE NOTE BELOW |
| Assembly weight..... | | 5.98 kg. |
| Force to collapse to minimum height (@ 0 BAR) | | 76 N. |

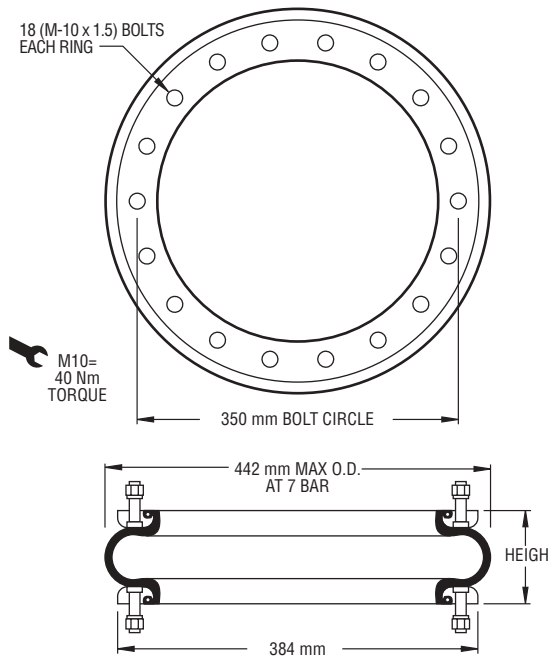

Static Data
6948

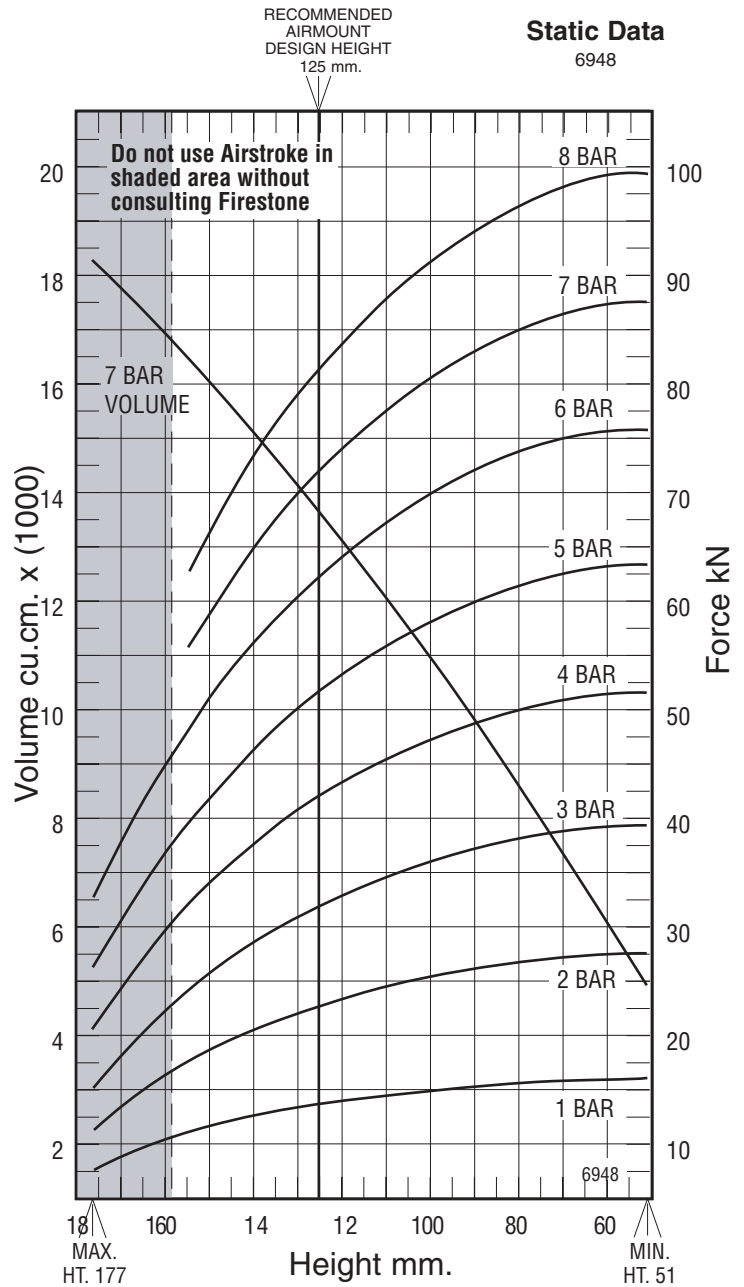

NOTE: A bead plate part is shown. This part is also available with rolled plates. See page 11 for explanation.

See page 12 for instructions on how to use chart.

| Gauge Pressure (BAR) | Load (kN) | Spring Rate (kN/m) | Natural Frequency Hz |
|----------------------|-----------|--------------------|----------------------|
| 3 | 26.86 | 599 | 2.35 |
| 4 | 36.82 | 766 | 2.27 |
| 5 | 46.53 | 934 | 2.23 |
| 6 | 57.15 | 1109 | 2.20 |
| 7 | 66.80 | 1269 | 2.17 |

| Assembly Height (mm) | Volume @ 7 BAR (cu cm) | EFF Area @ 7 BAR (cm sq) | kN Force | | | | |
|----------------------|------------------------|--------------------------|----------|---------|---------|---------|---------|
| | | | @ 3 BAR | @ 4 BAR | @ 5 BAR | @ 6 BAR | @ 7 BAR |
| 140 | 14081 | 847 | 23.26 | 32.31 | 40.96 | 50.59 | 59.29 |
| 130 | 13097 | 922 | 25.78 | 35.46 | 44.84 | 55.17 | 64.52 |
| 120 | 12133 | 982 | 27.78 | 37.99 | 47.98 | 58.85 | 68.74 |
| 110 | 11058 | 1033 | 29.48 | 40.18 | 50.67 | 62.00 | 72.34 |
| 100 | 10008 | 1075 | 30.83 | 41.97 | 52.85 | 64.53 | 75.23 |
| 90 | 8840 | 1110 | 31.99 | 43.53 | 54.73 | 66.70 | 77.72 |
| 80 | 7704 | 1139 | 32.96 | 44.81 | 56.25 | 68.45 | 79.72 |
| 70 | 6445 | 1162 | 33.79 | 45.85 | 57.48 | 69.86 | 81.34 |