

NOTE: All Assembly Order Numbers are for bead plate parts unless noted otherwise.

	Description	Assembly Order No.
Style 19-.75	Blind nuts, 1/4 BSP	W01-M58-6040
Two Ply Bellows		
Assembly weight (bead plate version, no bumper)		4.53 kg.
Force to collapse to minimum height (@ 0 BAR)		67 N.

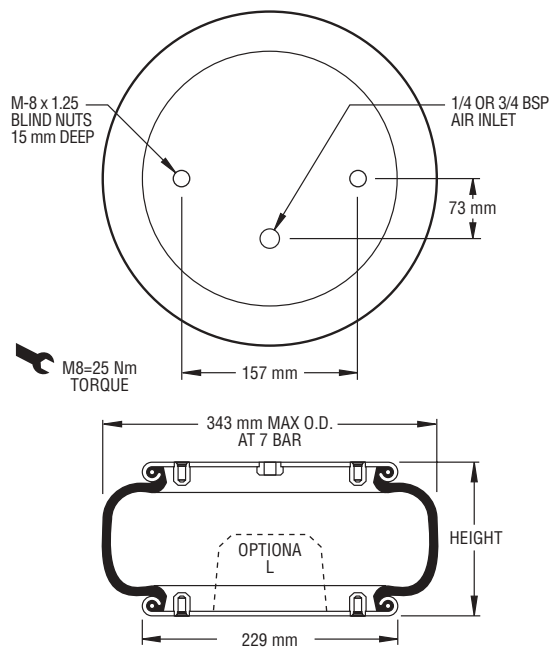

NOTE: A bead plate part is shown. This part is also available with bead rings. See pages 8-10 for explanation.

Dynamic Characteristics at 140 mm Design Height (Required for Airmount isolator design only)			
Gauge Pressure (BAR)	Load (kN)	Spring Rate (kN/m)	Natural Frequency Hz
3	9.30	272	2.70
4	12.89	356	2.62
5	16.44	435	2.57
6	20.49	514	2.50
7	24.11	589	2.46

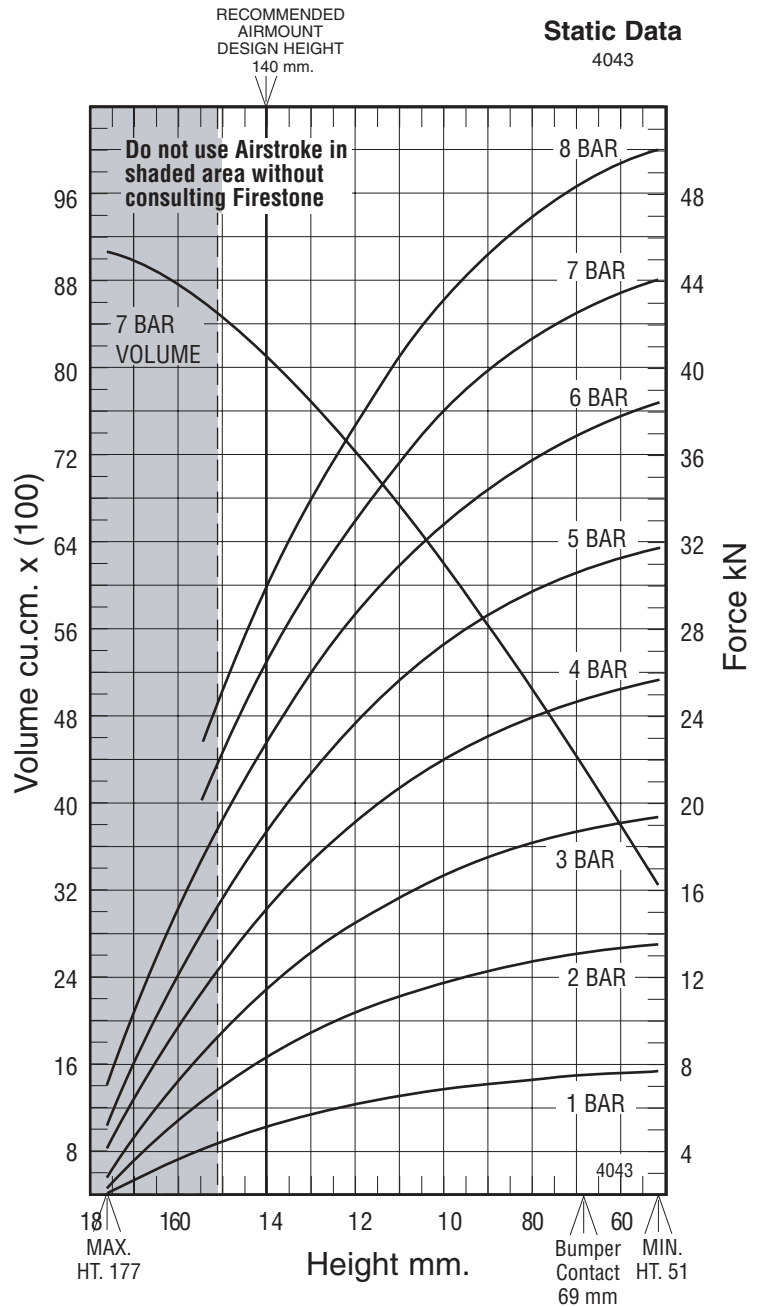

See page 12 for instructions on how to use chart.

Force Table (Use for Airstroke [®] actuator design)							
Assembly Height (mm)	Volume @ 7 BAR (cu cm)	EFF Area @ 7 BAR (cm sq)	kN Force				
			@ 3 BAR	@ 4 BAR	@ 5 BAR	@ 6 BAR	@ 7 BAR
140	7705	345	9.30	12.89	16.44	20.49	24.11
130	7286	397	11.01	15.15	19.21	23.73	27.81
120	6846	441	12.41	17.00	21.52	26.44	30.89
110	6335	480	13.64	18.63	23.55	28.84	33.62
100	5822	512	14.65	19.94	25.19	30.79	35.86
90	5243	540	15.50	21.06	26.57	32.45	37.80
80	4681	562	16.18	21.93	27.65	33.77	39.34
70	4063	580	16.73	22.65	28.54	34.84	40.60