

**NOTE: All Assembly Order Numbers are for bead plate parts unless noted otherwise.**

	Description	Assembly Order No.
Style 1T12E-3	Blind nuts, 1/4 BSP	W01-M58-6220
Two Ply Bellows	Socket head aluminum bead ring (bolts, nuts, washers not included, use cap screws)	SEE NOTE BELOW
Assembly weight.....		1.6 kg.

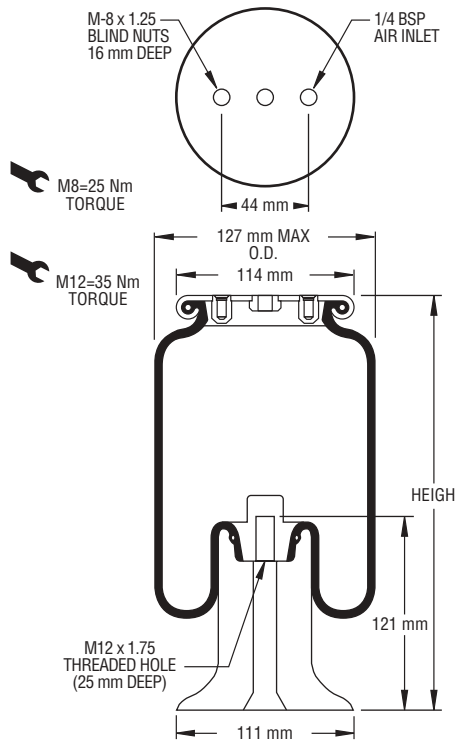

**NOTE: Bellows will not compress properly with less than .7 BAR internal pressure.**

**NOTE: A bead plate part is shown. This part is also available with a bead ring. Bolts are not included. See pages 8-10 for explanation.**

Dynamic Characteristics at 265 mm Design Height (Required for Airmount isolator design only)			
Gauge Pressure (BAR)	Load (kN)	Spring Rate (kN/m)	Natural Frequency Hz
3	1.43	12	1.43
4	1.95	13	1.29
5	2.44	16	1.29
6	2.98	19	1.26
7	3.50	21	1.21

CONSULT FIRESTONE BEFORE USING AS AIRMOUNT

RECOMMENDED AIRMOUNT DESIGN HEIGHT 265 mm.

**Static Data**  
9232

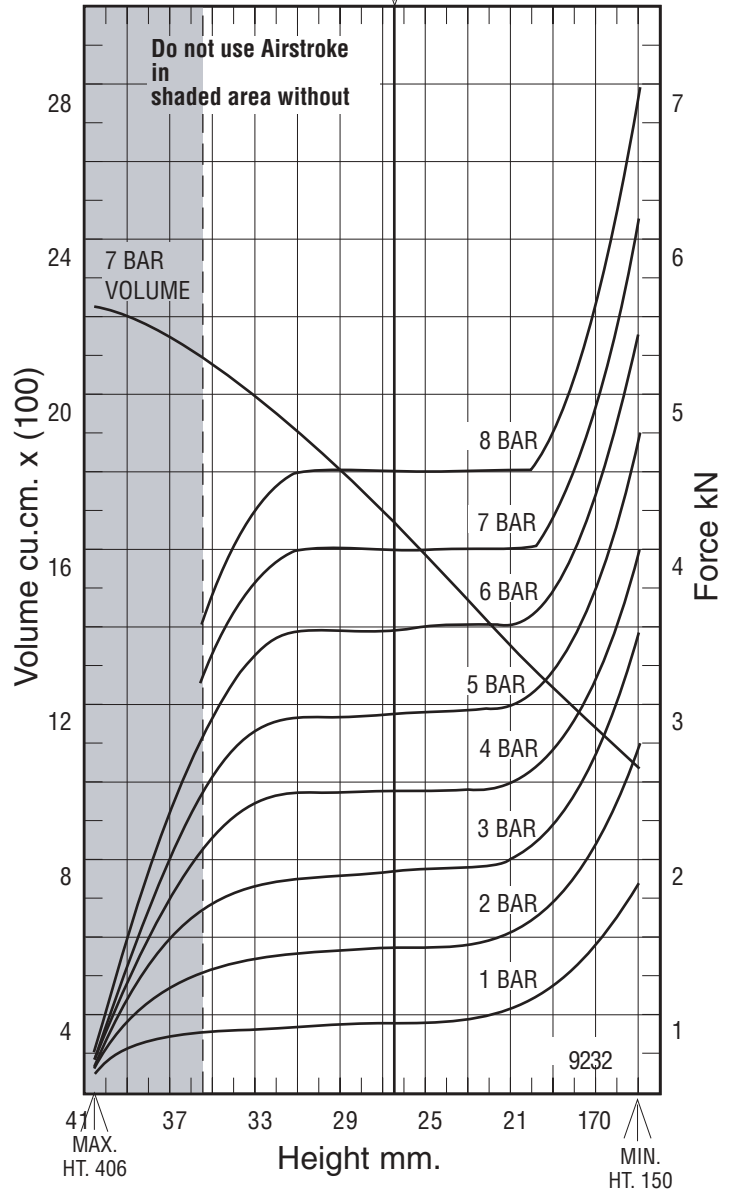

See page 12 for instructions on how to use chart.

**Force Table (Use for Airstroke® actuator design)**

Assembly Height (mm)	Volume @ 7 BAR (cu cm)	EFF Area @ 7 BAR (cm sq)	kN Force				
			@ 3 BAR	@ 4 BAR	@ 5 BAR	@ 6 BAR	@ 7 BAR
320	1753	49	1.37	1.92	2.40	2.92	3.41
300	1653	50	1.40	1.93	2.42	2.97	3.50
280	1550	50	1.40	1.93	2.42	2.97	3.50
260	1441	50	1.44	1.95	2.44	2.99	3.50
240	1329	50	1.45	1.95	2.46	3.01	3.50
220	1214	50	1.45	1.95	2.46	3.01	3.50
200	1100	50	1.59	2.07	2.56	3.05	3.52
180	988	58	1.93	2.39	2.94	3.49	4.03