

NOTE: All Assembly Order Numbers are for bead plate parts unless noted otherwise.

| | Description | Assembly Order No. |
|----------------------|-----------------------------|--------------------|
| Style 1T15L-4 | Blind nuts, 1/4 BSP | W01-M58-6255 |
| | Blind nuts, 1/4 BSP, bumper | W01-M58-6256 |
| Two Ply Bellows | | |
| Assembly weight..... | | 7.03 kg. |

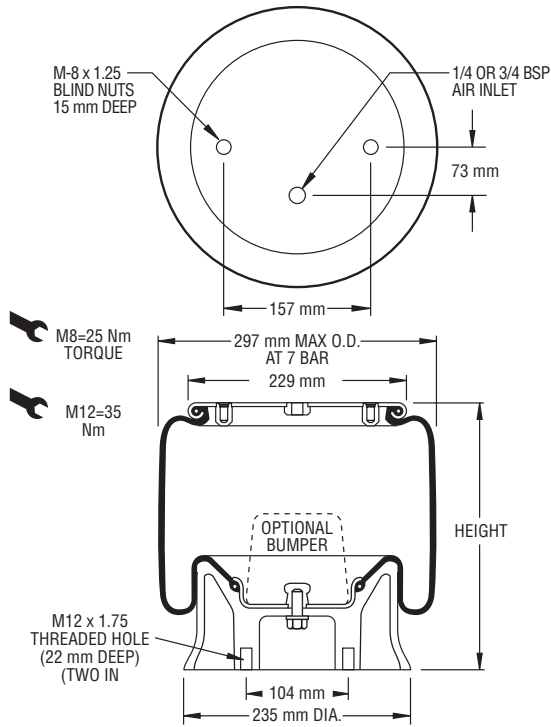

NOTE: Bellows will not compress properly with less than .7 BAR internal pressure.

NOTE: A bead plate part is shown. This part is also available with a bead ring. Bolts are not included. See pages 8-10 for explanation.

| Dynamic Characteristics at 280 mm Design Height (Required for Airmount isolator design only) | | | |
|---|-----------|--------------------|----------------------|
| Gauge Pressure (BAR) | Load (kN) | Spring Rate (kN/m) | Natural Frequency Hz |
| 3 | 13.03 | 110 | 1.45 |
| 4 | 17.73 | 140 | 1.40 |
| 5 | 22.31 | 170 | 1.38 |
| 6 | 27.14 | 202 | 1.36 |
| 7 | 31.57 | 230 | 1.35 |

CONSULT FIRESTONE BEFORE USING AS AIRMOUNT

RECOMMENDED AIRMOUNT DESIGN HEIGHT 280 mm.

Static Data
3105

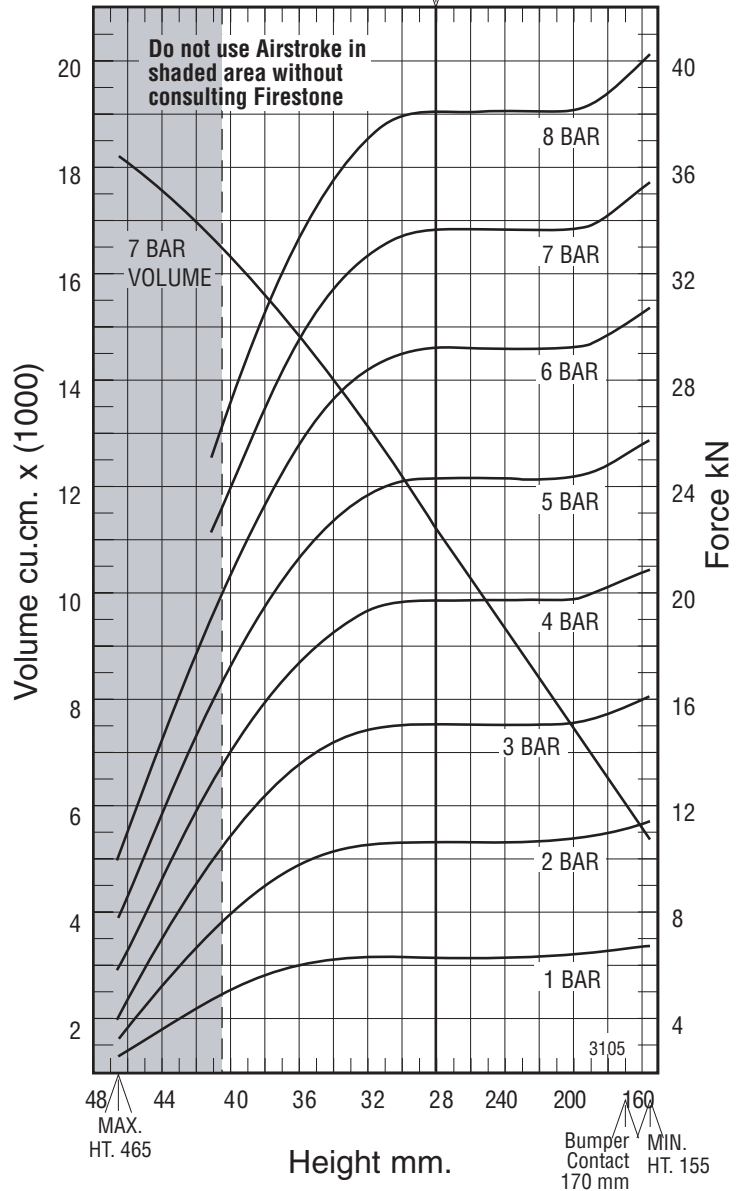

See page 12 for instructions on how to use chart.

| Force Table (Use for Airstroke® actuator design) | | | | | | | |
|--|------------------------|--------------------------|----------|---------|---------|---------|---------|
| Assembly Height (mm) | Volume @ 7 BAR (cu cm) | EFF Area @ 7 BAR (cm sq) | kN Force | | | | |
| | | | @ 3 BAR | @ 4 BAR | @ 5 BAR | @ 6 BAR | @ 7 BAR |
| 400 | 15364 | 309 | 8.65 | 11.78 | 14.94 | 18.45 | 21.61 |
| 360 | 13880 | 389 | 11.44 | 15.27 | 19.18 | 23.35 | 27.19 |
| 320 | 12139 | 437 | 12.81 | 17.24 | 17.65 | 26.30 | 30.58 |
| 280 | 10291 | 451 | 13.03 | 17.73 | 22.31 | 27.14 | 31.57 |
| 240 | 8407 | 451 | 13.03 | 17.73 | 22.31 | 27.14 | 31.57 |
| 200 | 6496 | 451 | 13.06 | 17.73 | 22.31 | 27.14 | 31.57 |
| 160 | 4628 | 472 | 13.96 | 18.72 | 23.46 | 28.45 | 33.06 |