

NOTE: All Assembly Order Numbers are for bead plate parts unless noted otherwise.

	Description	Assembly Order No.
Style	Blind nuts, 1/4 BSP	W01-M58-6265
1T15M-0	Blind nuts, 1/4 BSP, rubber bumper	W01-M58-6266
	Blind nuts, 3/4 BSP	W01-M58-6263
Two Ply Bellows	Blind nuts, 3/4 BSP, rubber bumper	W01-M58-6264
	Countersunk steel bead ring, 40 mm bolts, nuts, washers	SEE NOTE BELOW
Assembly weight.....		5.22 kg.

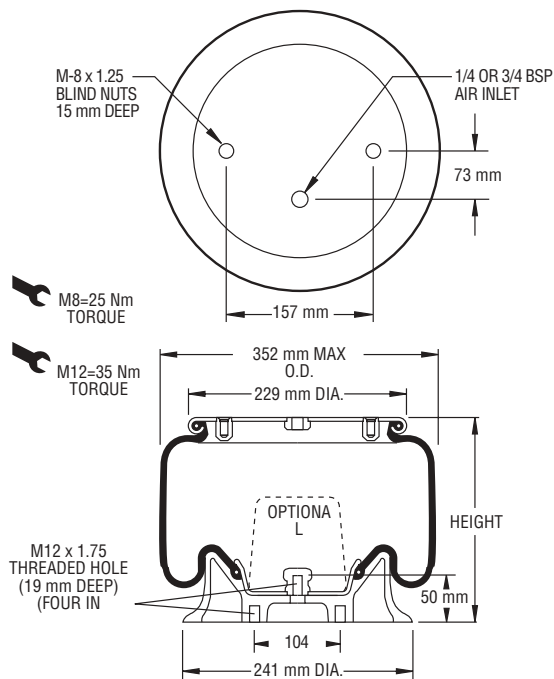

NOTE: Bellows will not compress properly with less than .7 BAR internal pressure.

NOTE: A bead plate part is shown. This part is also available with a bead ring. Bolts are not included. See pages 8-10 for explanation.

Gauge Pressure (BAR)	Load (kN)	Spring Rate (kN/m)	Natural Frequency Hz
3	12.85	149	1.70
4	17.59	189	1.63
5	22.14	228	1.60
6	27.03	270	1.58
7	31.53	307	1.56

CONSULT FIRESTONE BEFORE USING AS AIRMOUNT

RECOMMENDED AIRMOUNT DESIGN HEIGHT 190 mm. 8826

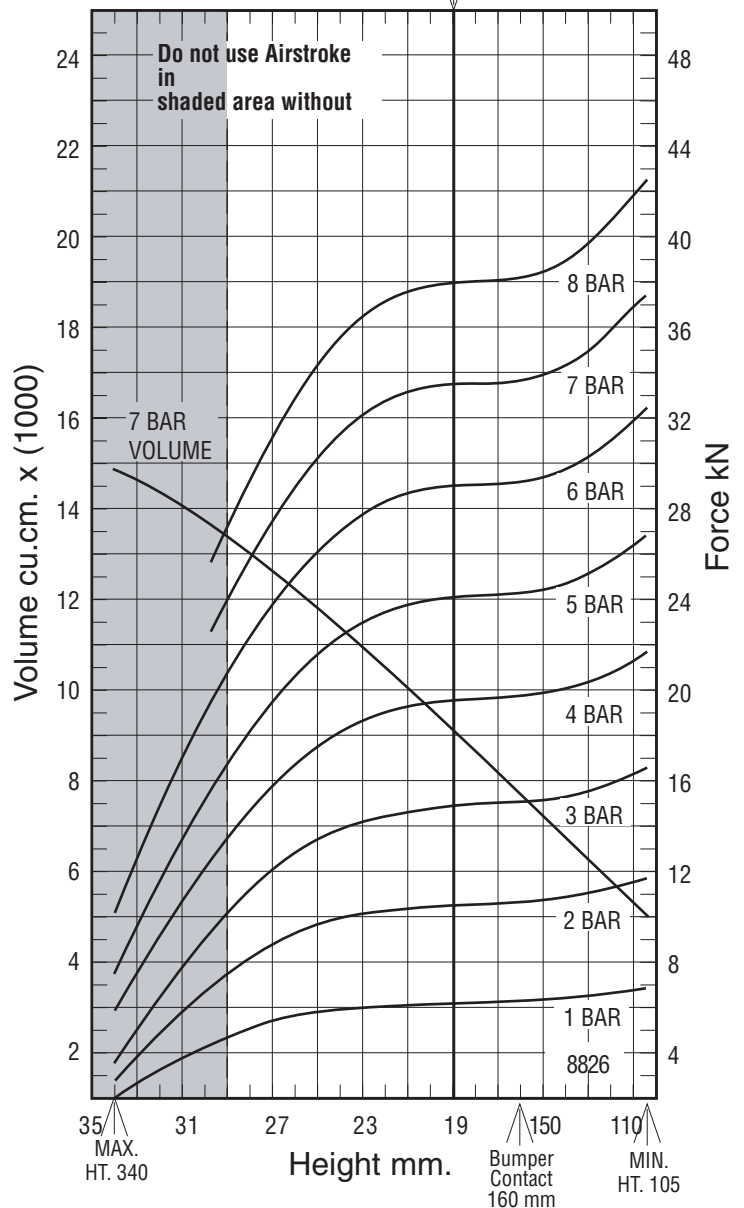

See page 12 for instructions on how to use chart.

Assembly Height (mm)	Volume @ 7 BAR (cu cm)	EFF Area @ 7 BAR (cm sq)	kN Force				
			@ 3 BAR	@ 4 BAR	@ 5 BAR	@ 6 BAR	@ 7 BAR
280	12080	337	9.10	12.52	15.98	19.99	23.58
260	11314	382	10.70	14.55	18.42	22.79	26.76
240	10488	417	11.79	16.07	20.26	24.90	29.16
220	9611	438	12.44	17.03	21.44	26.26	30.68
200	8667	449	12.76	17.50	22.01	26.90	31.39
180	7694	451	12.90	17.64	22.19	27.09	31.59
160	6704	453	13.02	17.73	22.31	27.22	31.73
140	5712	462	13.29	18.05	22.72	27.74	32.34