

NOTE: All Assembly Order Numbers are for bead plate parts unless noted otherwise.

	Description	Assembly Order No.
Style 1T15M-6	Blind nuts, 1/4 BSP	W01-M58-6290
	Blind nuts, 1/4 BSP, bumper	W01-M58-6291
Two Ply Bellows	Blind nuts, 3/4 BSP	W01-M58-6292
	Blind nuts, 3/4 BSP, bumper	W01-M58-6295
	Blind nuts, 3/4 BSP, (piston not included)	W01-M58-6294
Assembly weight.....		7.12 kg.

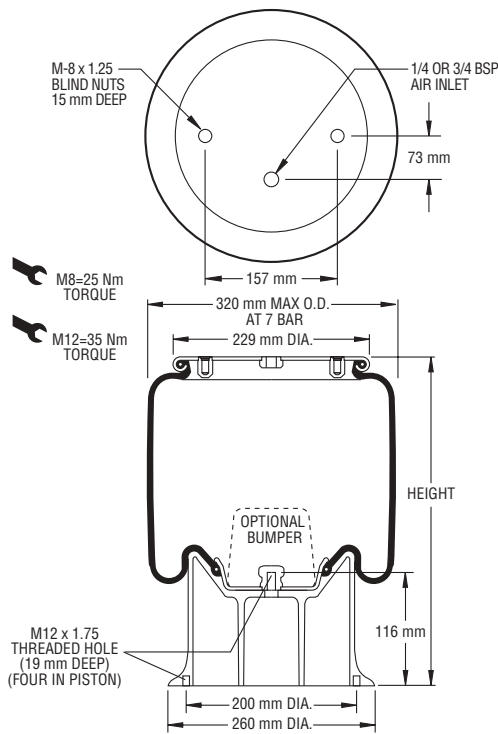

NOTE: Bellows will not compress properly with less than .7 BAR internal pressure.

NOTE: A bead plate part is shown. This part is also available with a bead ring. Bolts are not included. See pages 8-10 for explanation.

Gauge Pressure (BAR)	Load (kN)	Spring Rate (kN/m)	Natural Frequency Hz
3	13.01	72	1.18
4	17.68	93	1.14
5	22.25	111	1.11
6	27.16	129	1.09
7	31.66	147	1.07

CONSULT FIRESTONE BEFORE USING AS AIRMOUNT

RECOMMENDED AIRMOUNT DESIGN HEIGHT 380 mm.

Static Data
4452

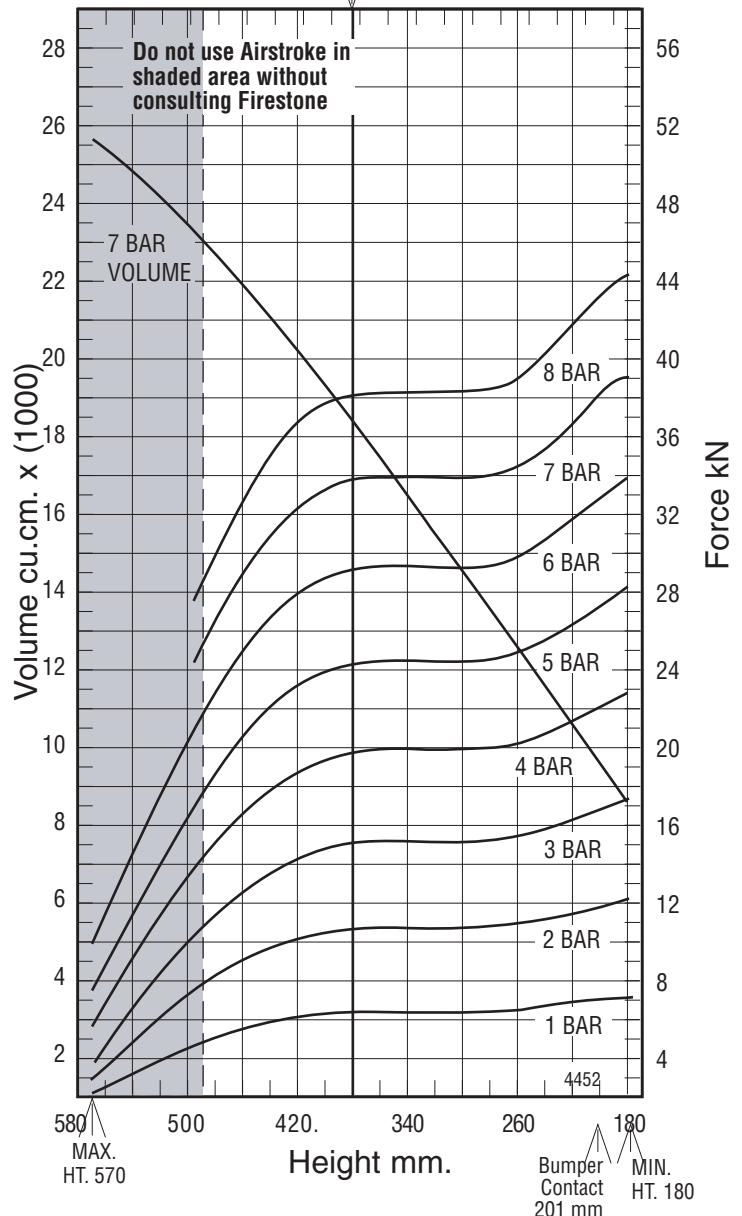

See page 12 for instructions on how to use chart.

Assembly Height (mm)	Volume @ 7 BAR (cu cm)	EFF Area @ 7 BAR (cm sq)	kN Force				
			@ 3 BAR	@ 4 BAR	@ 5 BAR	@ 6 BAR	@ 7 BAR
480	21723	347	9.30	12.91	16.49	20.60	24.25
440	20080	410	11.50	15.70	19.88	24.52	28.70
400	18349	445	12.73	17.31	21.82	26.70	31.16
360	16512	454	13.11	17.82	22.40	27.29	31.79
320	14536	454	13.12	17.83	22.40	27.29	31.79
280	12544	454	13.12	17.83	22.40	27.29	31.79
240	10569	476	13.72	18.54	23.35	28.53	33.28
200	8579	515	14.81	20.02	25.24	30.88	36.02