

NOTE: All Assembly Order Numbers are for bead plate parts unless noted otherwise.

	Description	Assembly Order No.
Style 21-2	Blind nuts, 1/4 BSP	W01-M58-6377
	Blind nuts, 1/4 BSP, rubber bumper	W01-M58-6379
Two Ply Bellows	Blind nuts, 3/4 BSP	W01-M58-6378
	Rubber bellows only	W01-358-0140
Assembly weight (bead plate version, no bumper)		8.26kg.
Force to collapse to minimum height (@ 0 BAR)		156 N.

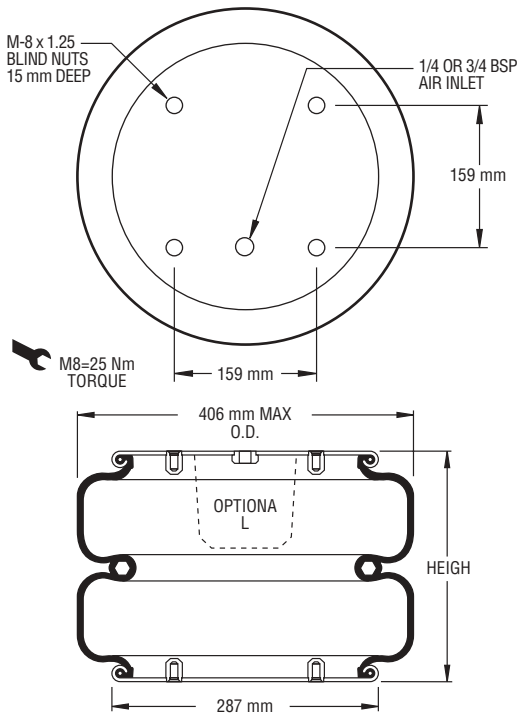

NOTE: The bellows extends beyond the bead plates at minimum height.

NOTE: A bead plate part is shown. This part is also available with bead rings. See pages 8-10 for explanation.

Dynamic Characteristics at 265 mm Design Height (Required for Airmount isolator design only)			
Gauge Pressure (BAR)	Load (kN)	Spring Rate (kN/m)	Natural Frequency Hz
3	16.48	183	1.66
4	22.69	238	1.62
5	28.70	289	1.58
6	35.33	340	1.55
7	41.34	390	1.53

Static Data
3931

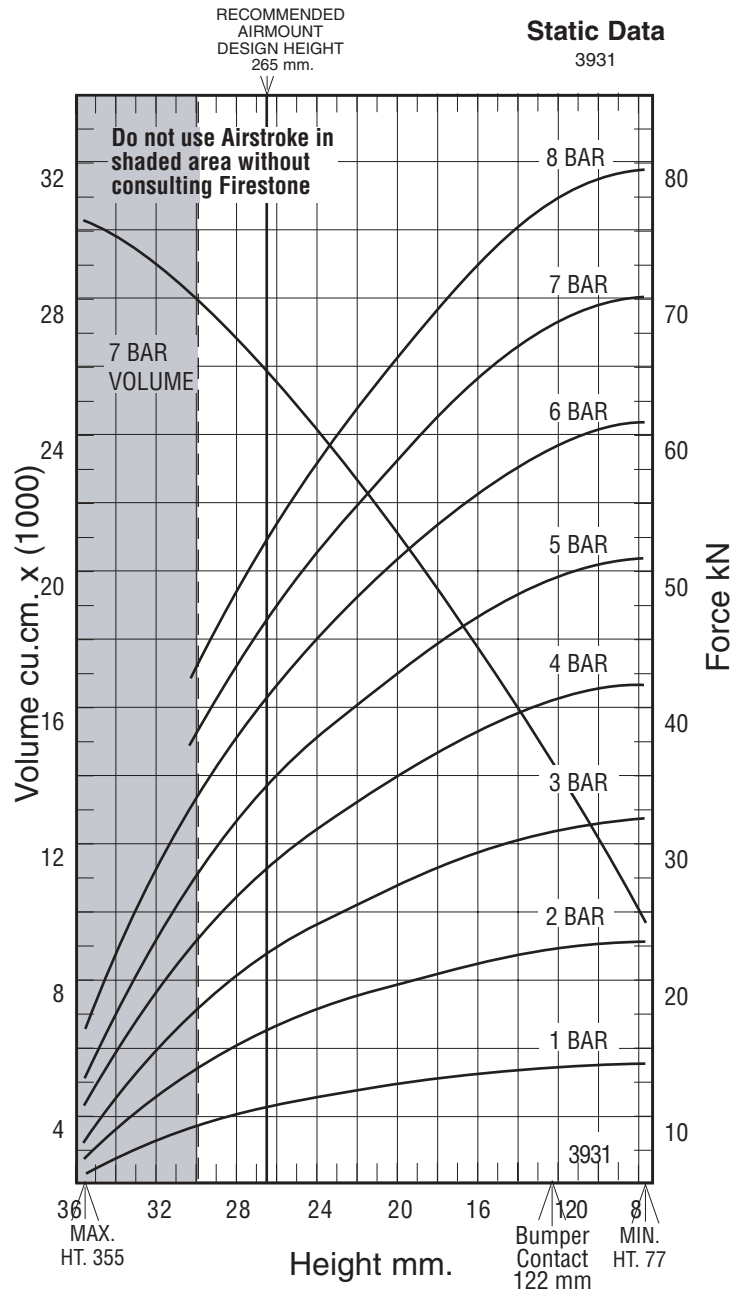

See page 12 for instructions on how to use chart.

Force Table (Use for Airstroke [®] actuator design)							
Assembly Height (mm)	Volume @ 7 BAR (cu cm)	EFF Area @ 7 BAR (cm sq)	kN Force				
			@ 3 BAR	@ 4 BAR	@ 5 BAR	@ 6 BAR	@ 7 BAR
280	24758	541	14.81	20.52	26.07	32.28	37.85
240	22165	661	18.76	25.69	32.37	39.60	46.23
200	19084	758	21.74	29.70	37.34	45.53	53.06
160	15583	844	24.15	33.09	41.57	50.69	59.10
120	11862	906	25.90	35.57	44.61	54.37	63.44
80	8016	930	26.79	36.66	45.89	55.82	65.11