

NOTE: All Assembly Order Numbers are for bead ring parts unless noted otherwise.

	Description	Assembly Order No.
Style 215	Ribbed neck aluminum bead rings (equal spacing), 45 mm bolts, nuts, washers	W01-M58-6978
High Strength Construction	Rubber bellows only	W01-358-7912
Assembly weight.....		17.42 kg.
Force to collapse to minimum height (@ 0 BAR)		712 N.

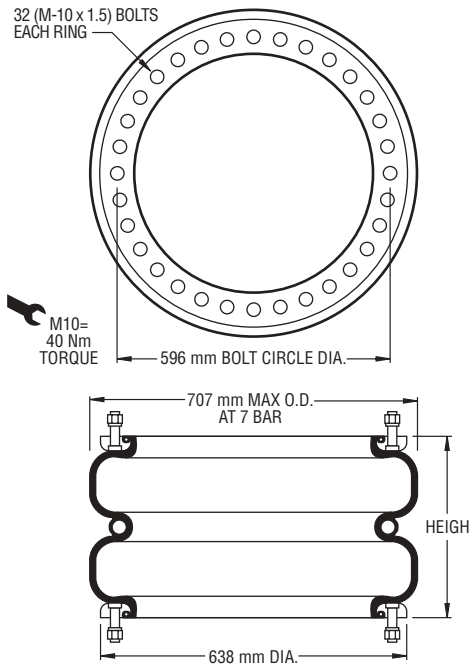

Static Data
3560

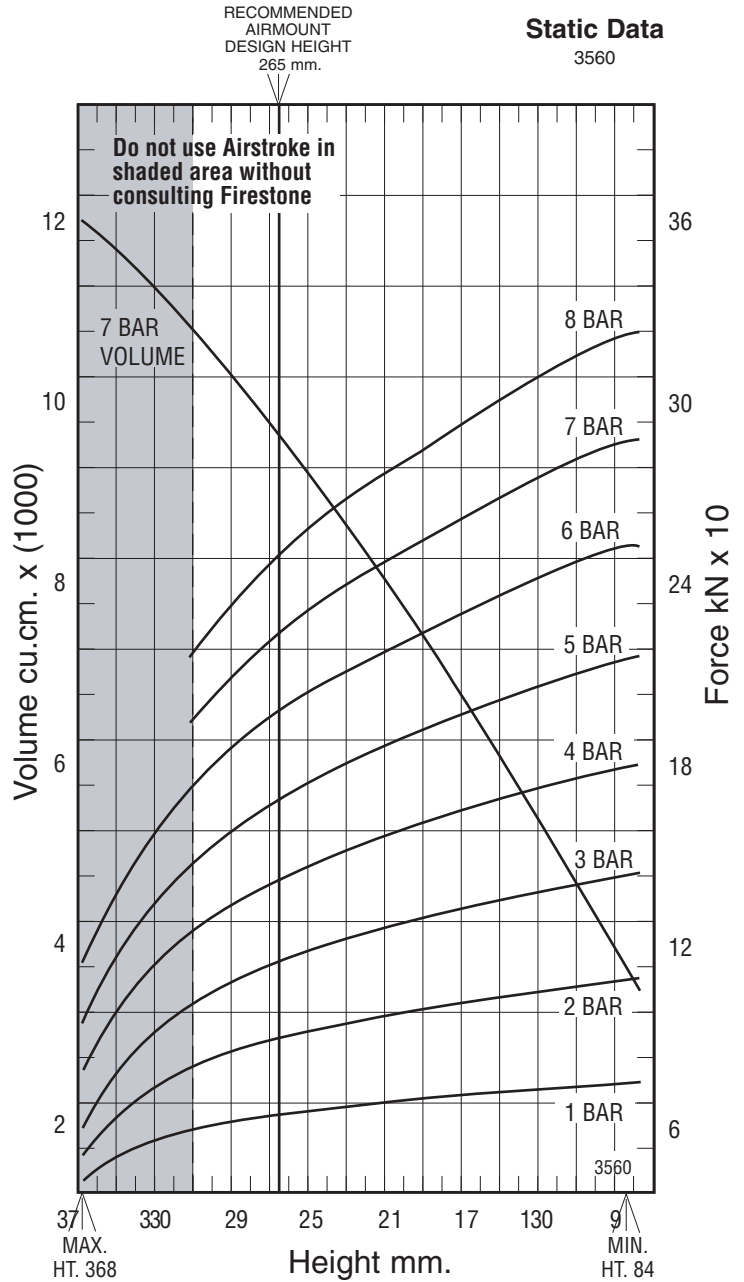

See page 12 for instructions on how to use chart.

Dynamic Characteristics at 265 mm Design Height
(Required for Airmount isolator design only)

Gauge Pressure (BAR)	Load (kN)	Spring Rate (kN/m)	Natural Frequency Hz
3	75.98	710	1.52
4	103.39	879	1.45
5	130.16	1077	1.43
6	158.58	1277	1.42
7	184.57	1458	1.40

Force Table (Use for Airstroke[®] actuator design)

Assembly Height (mm)	Volume @ 7 BAR (cu cm)	EFF Area @ 7 BAR (cm sq)	kN Force				
			@ 3 BAR	@ 4 BAR	@ 5 BAR	@ 6 BAR	@ 7 BAR
280	87025	2517	71.76	98.42	123.96	151.24	176.18
240	76206	2804	81.69	110.16	138.72	168.82	196.27
200	64214	3026	88.70	119.39	150.17	182.38	211.83
160	51165	3225	94.30	127.88	160.34	194.31	225.73
120	37635	3424	100.33	135.61	169.95	206.11	239.66
80	23815	3558	105.77	141.44	177.04	214.33	249.02