

NOTE: All Assembly Order Numbers are for bead ring parts unless noted otherwise.

	Description	Assembly Order No.
Style 28	Ribbed neck aluminum bead rings (equal spacing), 45 mm bolts, nuts, washers	W01-M58-7531
Two Ply Bellows	Rolled plate assembly, 1/2 blind nuts, 3/4 NPT	SEE NOTE BELOW
	Rubber bellows only	W01-358-7925
Assembly weight.....		8.62 kg.
Force to collapse to minimum height (@ 0 BAR)		169 N.

Style 201	Ribbed neck aluminum bead rings (equal spacing), 50 mm bolts, nuts, washers	Contact Firestone W01-358-0201
High Strength Construction	Rubber bellows only	

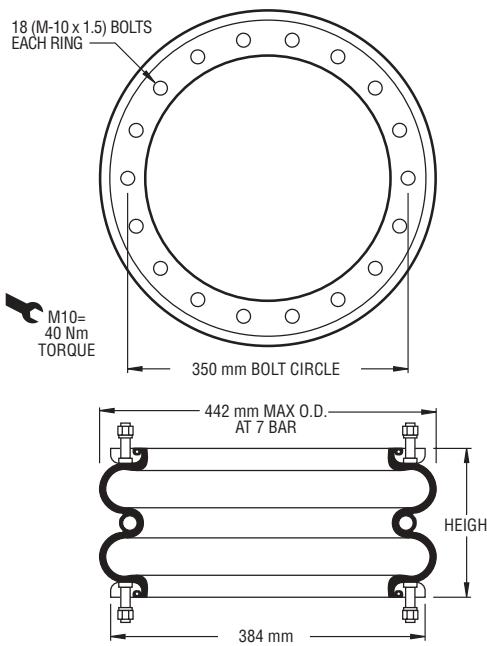

NOTE: A bead ring part is shown. This part is also available with rolled plates. See page 11 for explanation.

Gauge Pressure (BAR)	Load (kN)	Spring Rate (kN/m)	Natural Frequency Hz
3	22.15	295	1.82
4	30.14	376	1.76
5	38.05	460	1.73
6	46.65	542	1.70
7	54.48	618	1.68

Static Data
5526

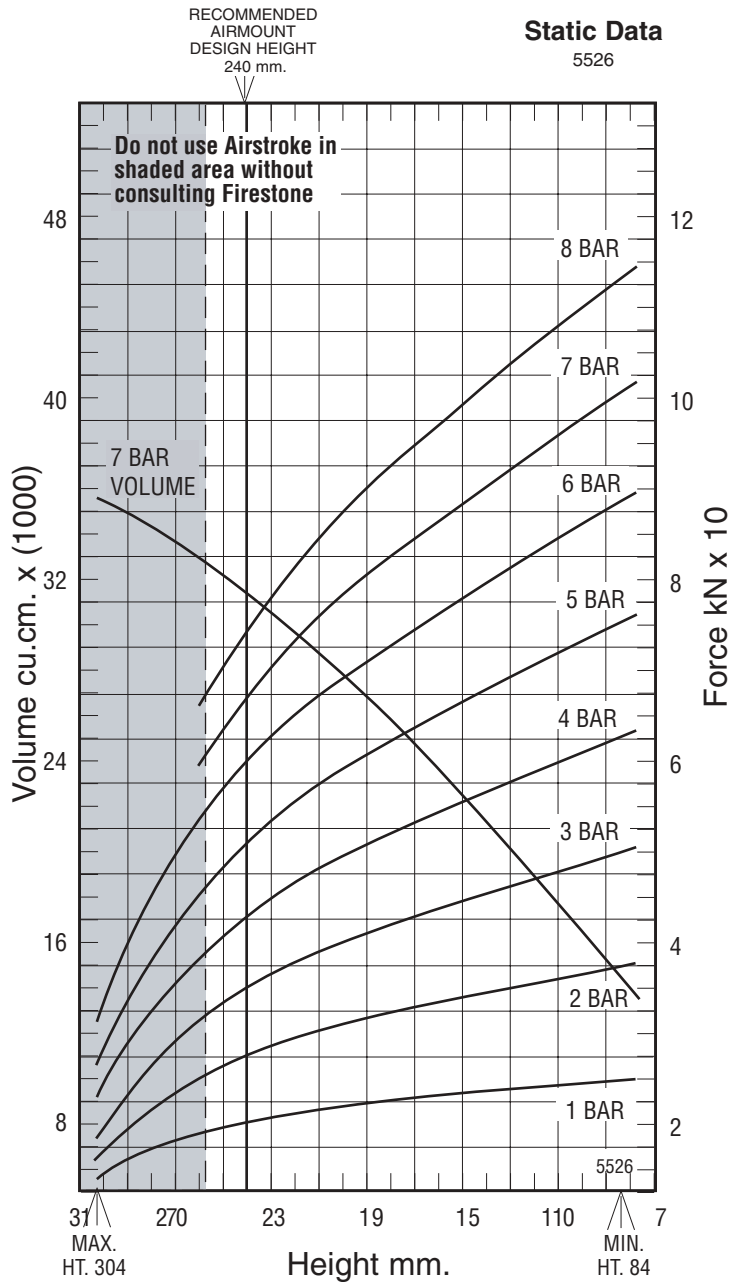

See page 12 for instructions on how to use chart.

Assembly Height (mm)	Volume @ 7 BAR (cu cm)	EFF Area @ 7 BAR (cm sq)	kN Force				
			@ 3 BAR	@ 4 BAR	@ 5 BAR	@ 6 BAR	@ 7 BAR
240	26073	778	22.15	30.14	38.05	46.65	54.48
220	24364	868	25.13	33.95	42.75	52.16	60.76
200	22432	942	27.57	37.08	46.61	56.69	65.96
180	20346	1006	29.58	39.70	49.85	60.54	70.38
160	18120	1062	31.33	42.02	52.74	63.99	74.36
140	15772	1118	32.97	44.25	55.56	67.37	78.24
120	13395	1175	34.68	46.56	58.50	70.87	82.21
100	10932	1231	36.48	48.90	61.43	74.35	86.18