

NOTE: All Assembly Order Numbers are for bead plate parts unless noted otherwise.

CONSULT
FIRESTONE BEFORE
USING AS AIRMOUNT

RECOMMENDED
AIRMOUNT
DESIGN HEIGHT
375 mm.

Static Data
8695

	Description	Assembly Order No.
Style 333	Blind nuts, 1/4 BSP	W01-M58-6136
	Blind nuts, 1/4 BSP, rubber bumper	W01-M58-6138
Two Ply Bellows	Blind nuts, 3/4 BSP	W01-M58-6137
	Countersunk steel bead rings 40 mm bolts, nuts, washers	W01-M58-7535
	Rubber bellows only	W01-358-7019
Assembly weight.....		11.16 kg.
Force to collapse to minimum height (@ 0 BAR)		289 N.

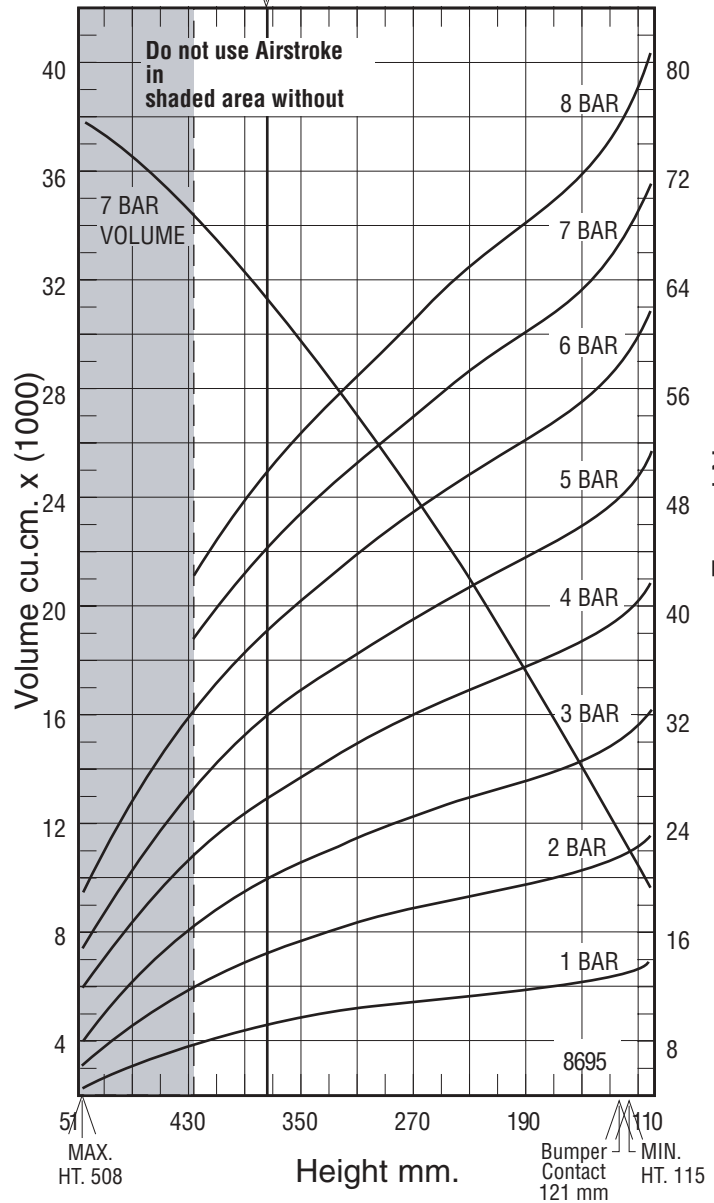
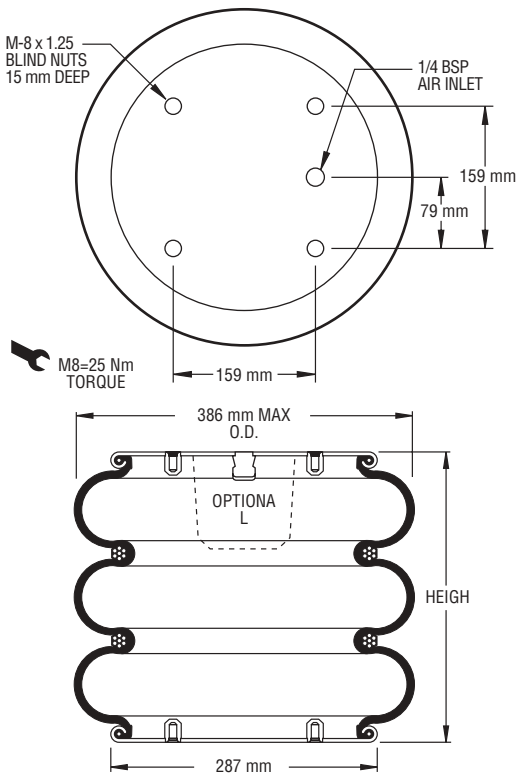

NOTE: A bead plate part is shown. This part is also available with bead rings. See pages 8-10 for explanation.

See page 12 for instructions on how to use chart.

Gauge Pressure (BAR)	Load (kN)	Spring Rate (kN/m)	Natural Frequency Hz
3	15.75	115	1.35
4	21.81	148	1.30
5	27.65	179	1.27
6	34.16	210	1.24
7	40.04	239	1.22

Assembly Height (mm)	Volume @ 7 BAR (cu cm)	EFF Area @ 7 BAR (cm sq)	kN Force				
			@ 3 BAR	@ 4 BAR	@ 5 BAR	@ 6 BAR	@ 7 BAR
420	31923	492	12.82	18.18	23.24	29.16	34.43
380	29684	565	15.48	21.47	27.24	33.69	39.51
340	27147	623	17.53	24.08	30.38	37.29	43.60
300	24321	676	19.30	26.37	33.16	40.53	47.32
260	21367	727	20.90	28.46	35.74	43.60	50.87
220	18224	773	22.32	30.31	38.06	46.41	54.12
180	14802	815	23.58	31.93	40.12	48.91	57.03
140	11225	864	25.14	33.87	42.56	51.89	60.49