

**NOTE: All Assembly Order Numbers are for bead plate parts unless noted otherwise.**

CONSULT FIRESTONE BEFORE USING AS AIRMOUNT

RECOMMENDED AIRMOUNT DESIGN HEIGHT 340 mm.

**Static Data**  
4789

	Description	Assembly Order No.
Style 352	Blind nuts, 1/4 BSP	W01-M58-6129
	Blind nuts, 3/4 BSP	W01-M58-6128
Two Ply Bellows		
Assembly weight.....		8.84 kg.
Force to collapse to minimum height (@ 0 BAR)		900 N.

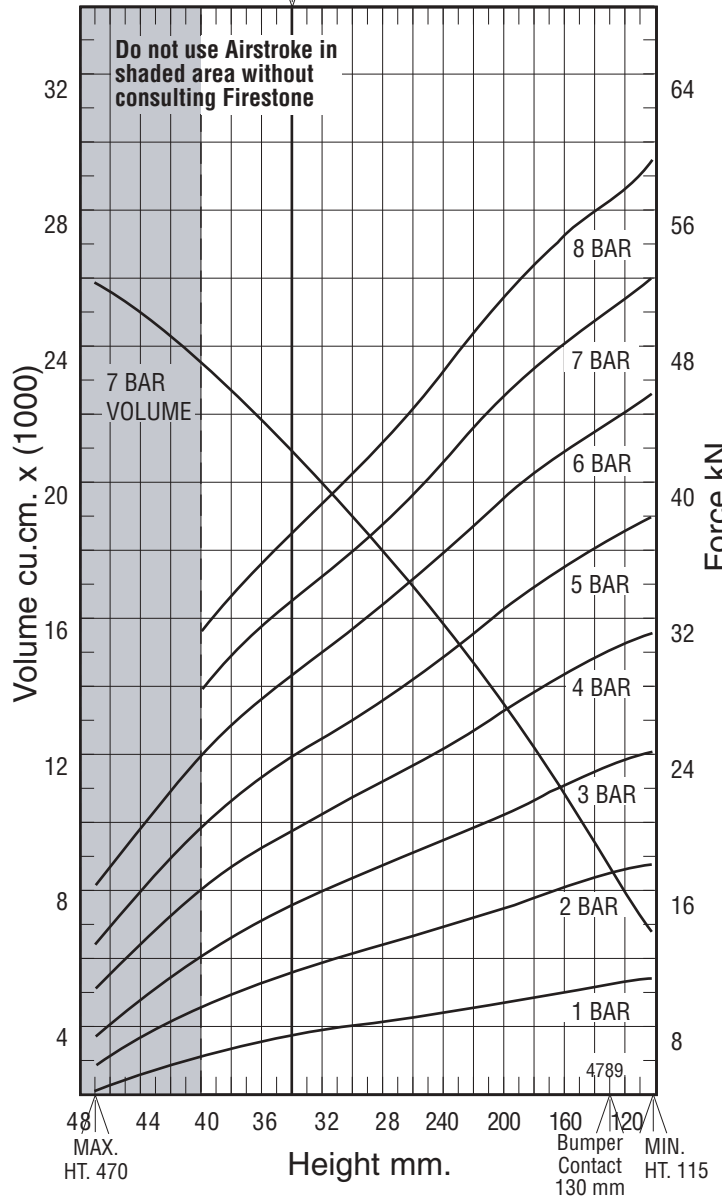
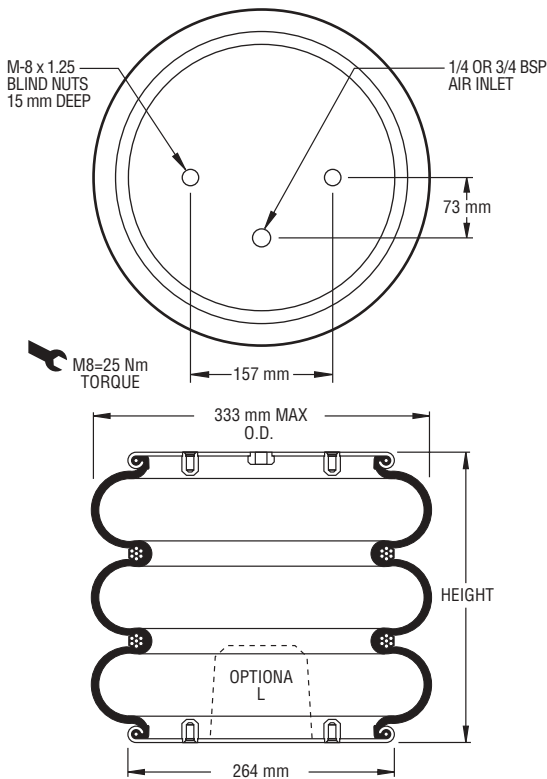

**NOTE: A bead plate part is shown. This part is also available with bead rings. See pages 8-10 for explanation.**

See page 12 for instructions on how to use chart.

Gauge Pressure (BAR)	Load (kN)	Spring Rate (kN/m)	Natural Frequency Hz
3	11.29	94	1.44
4	15.70	115	1.35
5	20.02	140	1.32
6	24.85	165	1.28
7	29.14	188	1.27

Assembly Height (mm)	Volume @ 7 BAR (cu cm)	EFF Area @ 7 BAR (cm sq)	kN Force				
			@ 3 BAR	@ 4 BAR	@ 5 BAR	@ 6 BAR	@ 7 BAR
380	20777	370	9.42	13.56	17.44	21.95	25.89
340	19038	416	11.29	15.70	20.02	24.85	29.14
300	17069	459	12.88	17.53	22.29	27.49	32.13
260	14972	508	14.35	19.46	24.70	30.43	35.55
220	12695	563	15.87	21.65	27.37	33.68	39.40
180	10161	614	17.50	23.87	30.03	36.76	42.96
140	7445	652	19.13	25.76	32.28	39.20	45.65