

	Description	Assembly Order No.
Style 4001	Blind nuts, 1/8 NPT	W02-358-4001
Two Ply Bellows		
Assembly weight45 kg.		

NOTE: Standard assembly is imperial.

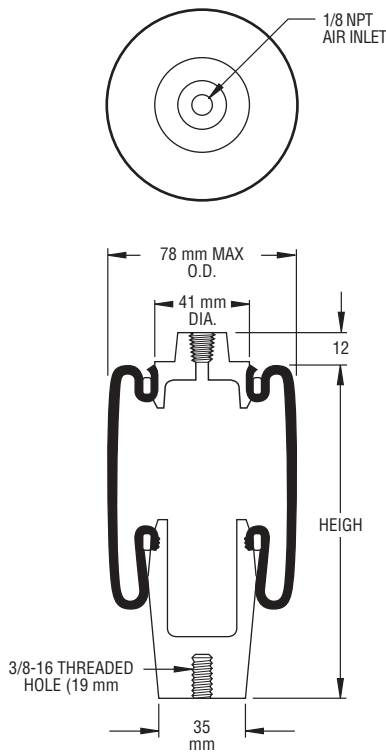

NOTE: Bellows will not compress properly with less than .7 BAR internal pressure.

Dynamic Characteristics at 140 mm Design Height (Required for Airmount isolator design only)			
Gauge Pressure (BAR)	Load (kN)	Spring Rate (kN/m)	Natural Frequency Hz
3	.68	9	1.82
4	.95	12	1.74
5	1.21	14	1.68
6	1.51	16	1.65
7	1.78	19	1.63

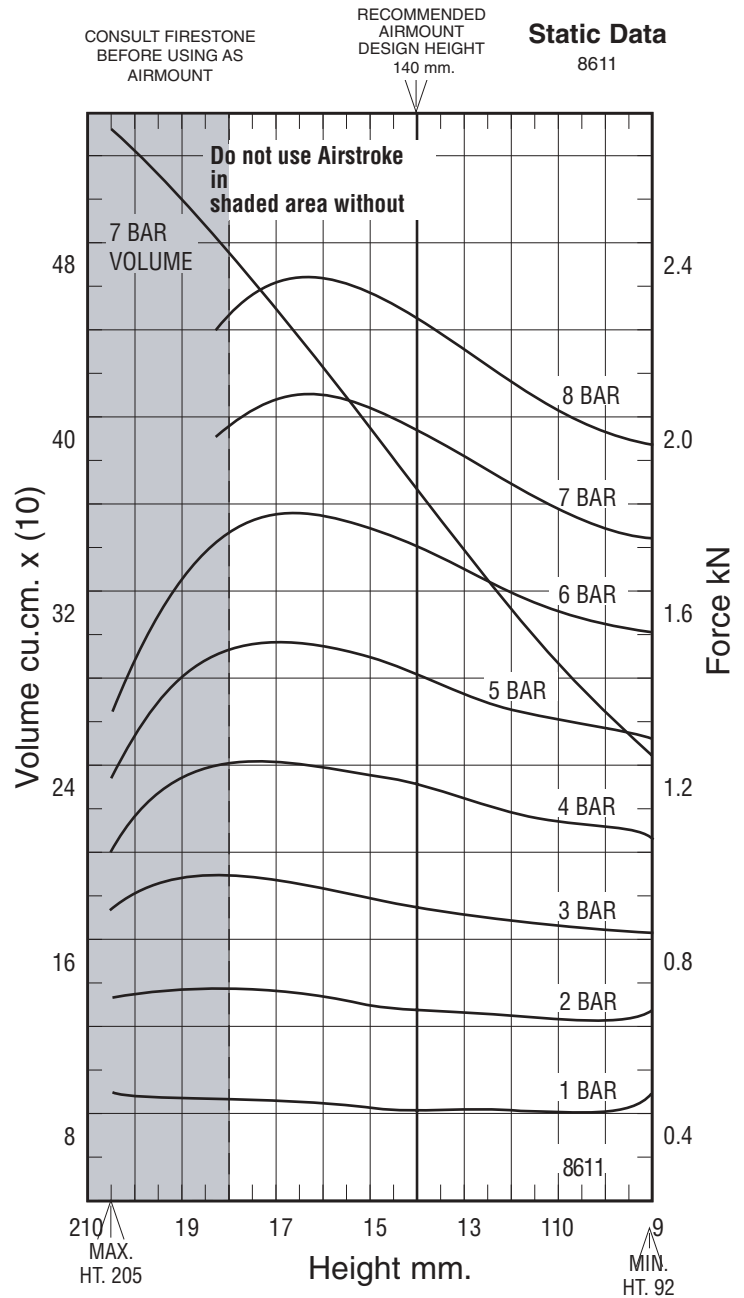

See page 12 for instructions on how to use chart.

Force Table (Use for Airstroke® actuator design)							
Assembly Height (mm)	Volume @ 7 BAR (cu cm)	EFF Area @ 7 BAR (cm sq)	kN Force				
			@ 3 BAR	@ 4 BAR	@ 5 BAR	@ 6 BAR	@ 7 BAR
180	438	25	.74	1.01	1.26	1.53	1.78
170	411	26	.74	1.01	1.28	1.58	1.84
160	383	26	.72	1.00	1.27	1.58	1.85
150	355	26	.70	.98	1.25	1.55	1.82
140	325	25	.68	.95	1.21	1.51	1.78
130	297	24	.66	.92	1.17	1.45	1.71
120	272	24	.65	.90	1.13	1.40	1.65
110	246	23	.64	.88	1.11	1.36	1.59
100	225	22	.63	.86	1.09	1.33	1.55