

	Description	Assembly Order No.
Style 7010	Blind nuts, 1/8 NPT	W02-358-7010
Two Ply Bellows		
Assembly weight.....		.73 kg.

**NOTE: Standard assembly is imperial.**

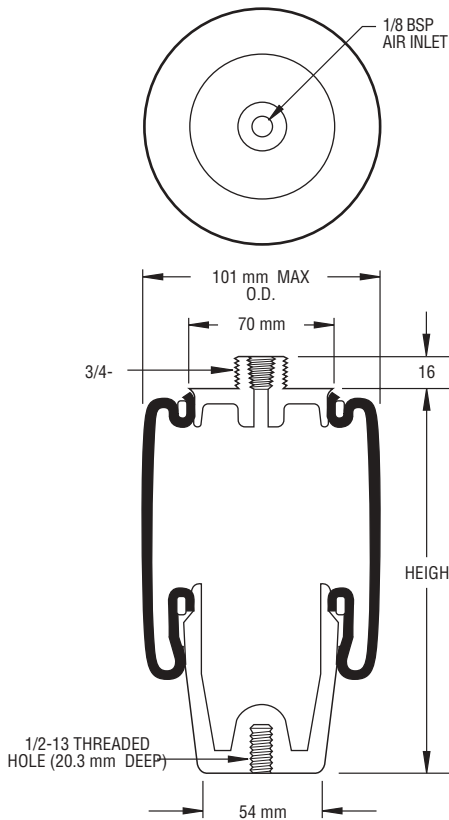

**NOTE: Bellows will not compress properly with less than .7 BAR internal pressure.**

Gauge Pressure (BAR)	Load (kN)	Spring Rate (kN/m)	Natural Frequency Hz
3	1.41	8	1.18
4	1.99	10	1.11
5	2.55	13	1.14
6	3.17	17	1.14
7	3.72	18.5	1.11

CONSULT FIRESTONE BEFORE USING AS AIRMOUNT

RECOMMENDED AIRMOUNT DESIGN HEIGHT 205 mm.

**Static Data**  
8612

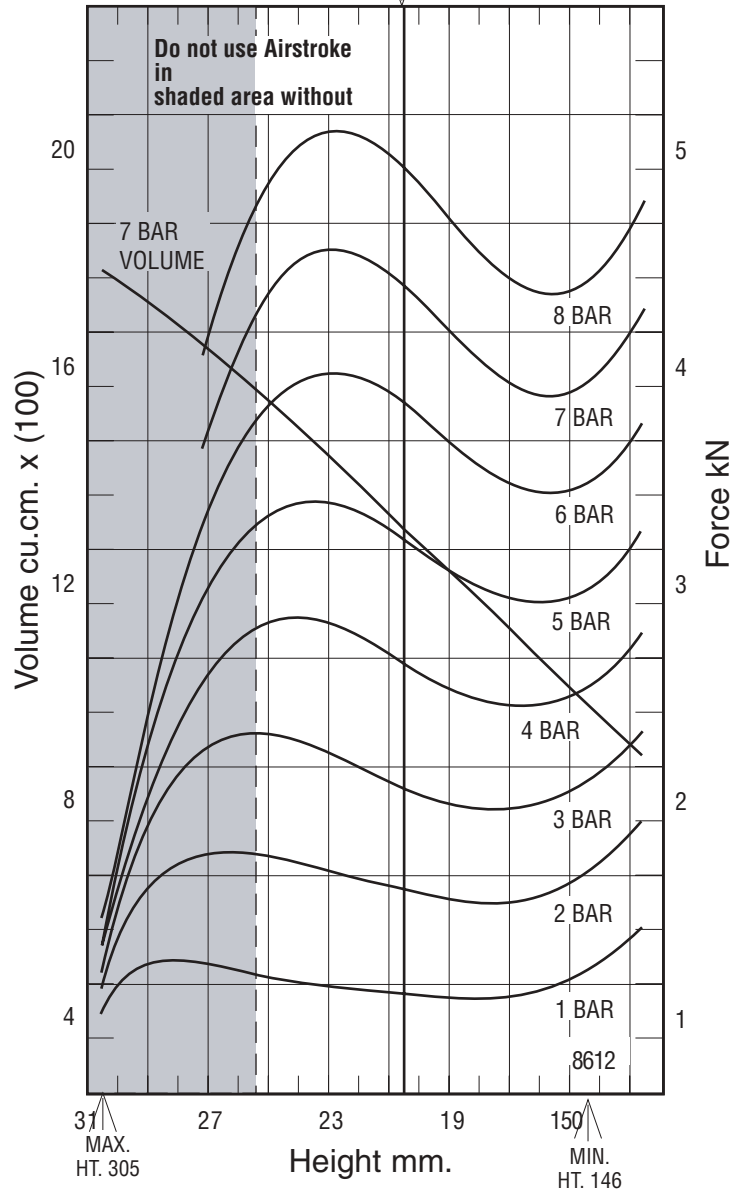

See page 12 for instructions on how to use chart.

Assembly Height (mm)	Volume @ 7 BAR (cu cm)	EFF Area @ 7 BAR (cm sq)	kN Force				
			@ 3 BAR	@ 4 BAR	@ 5 BAR	@ 6 BAR	@ 7 BAR
260	1321	48	1.65	2.08	2.52	2.95	3.39
240	1224	55	1.63	2.18	2.71	3.27	3.82
220	1123	55	1.51	2.10	2.66	3.29	3.86
200	1016	52	1.39	1.95	2.50	3.12	3.66
180	906	48	1.31	1.81	2.33	2.90	3.38
160	798	46	1.33	1.78	2.25	2.76	3.21