

Assembly Order No.	Rubber Material	F1	F2	F3	Clamp Ring	Body Material	Max Restricted Pressure (psig/bar)	Max Unrestricted Pressure (psig/bar)
WP1-M58-0004	Neoprene	M5	M5	N/A	Stainless Steel	Steel	70 / 5	25 / 1.8
WP1-358-2000	Neoprene	10-32 UNF	10-32 UNF	N/A	Stainless Steel	Steel	70 / 5	25 / 1.8

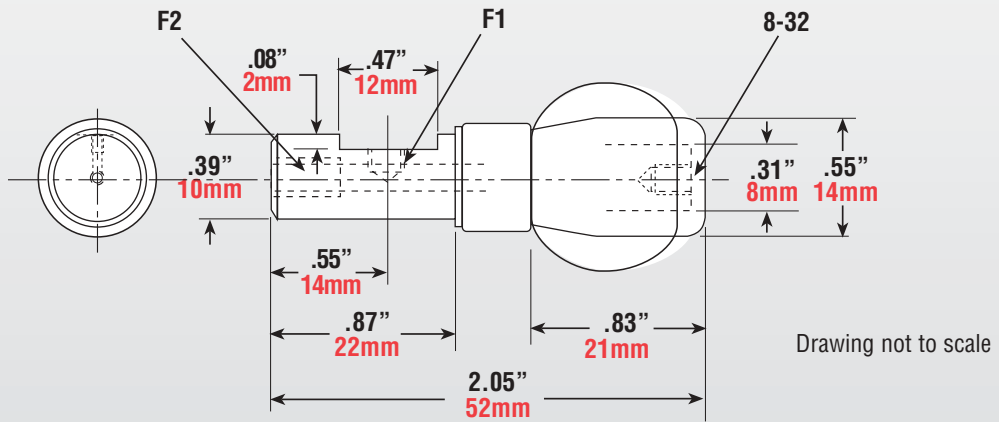

IMPERIAL

FORCE CURVES

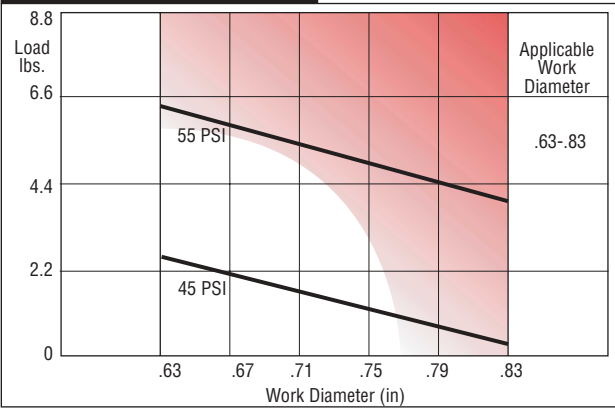

PRESSURE VS INFLATED DIAMETER

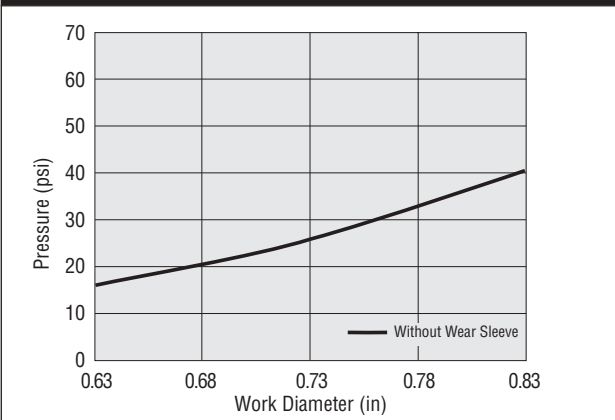

METRIC

FORCE CURVES

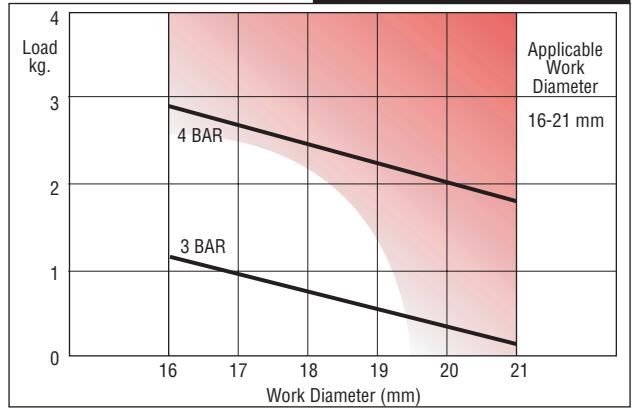

PRESSURE VS INFLATED DIAMETER

