

Assembly Order No.	Rubber Material	F1	F2	F3	Clamp Ring	Body Material	Max Restricted Pressure (psig/bar)	Max Unrestricted Pressure (psig/bar)
WP1-M58-0012	Neoprene	M6	M6	M6	Stainless Steel	Aluminum	70 / 5	35 / 2.4
WP1-358-2007	Neoprene	1/8-27 NPT	1/8-27 NPT	10-24 UNC	Stainless Steel	Aluminum	70 / 5	35 / 2.4

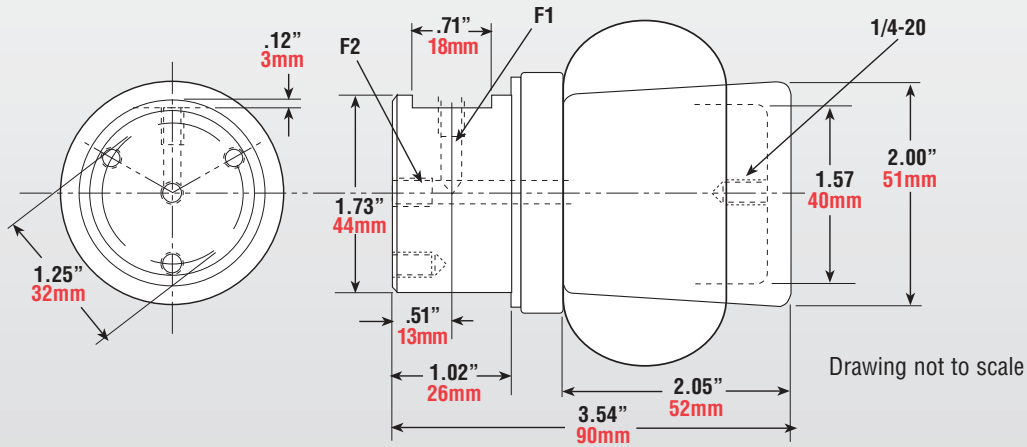

IMPERIAL

METRIC

FORCE CURVES

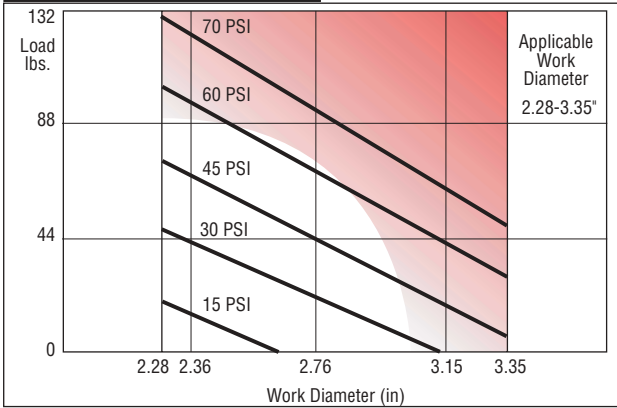

FORCE CURVES

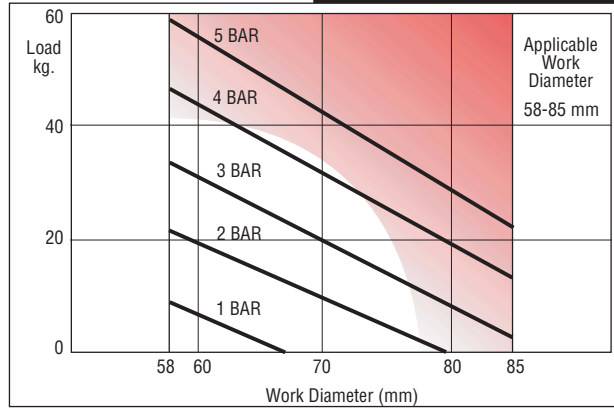

PRESSURE VS INFLATED DIAMETER

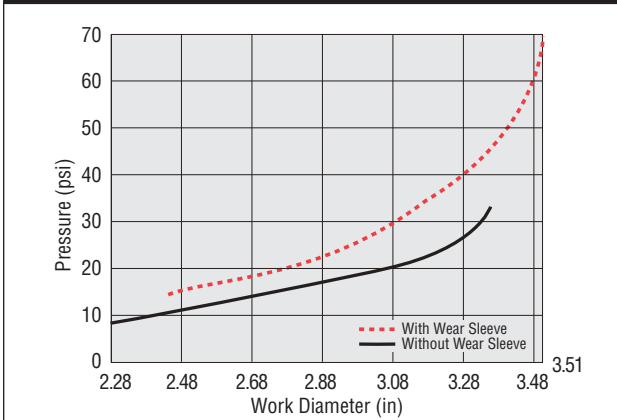

PRESSURE VS INFLATED DIAMETER

